

MANUAL DE MONTAGEM
Assembly instructions / Instrucciones de armado

MESA MANAUS

Office table Manaus
Escritorio Manaus

Código 1222 Revisão 01

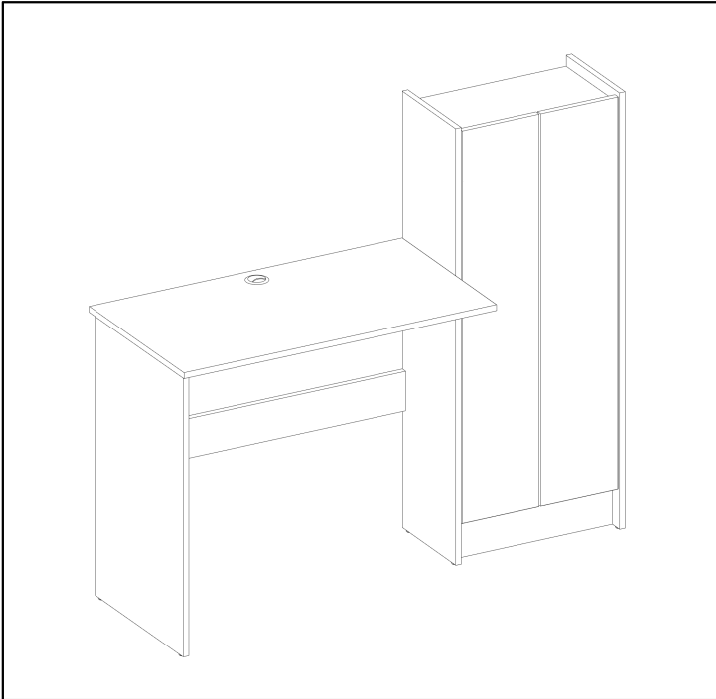

PESO MÁXIMO SUPORTADO PELAS PEÇAS, SENDO ESTE DISTRIBUÍDO UNIFORMEMENTE.

Maximum weight supported by parts, being this evenly distributed.
Peso máximo soportado por las partes, siendo esta distribuido uniformemente.

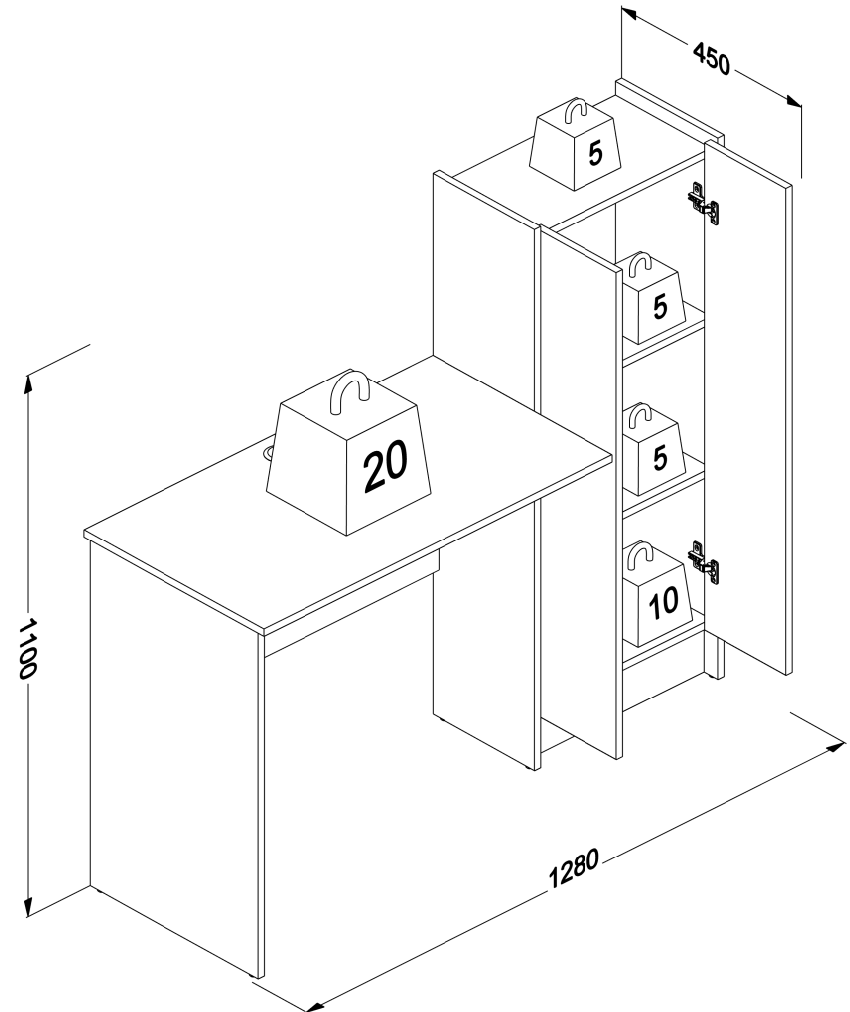

Você vai precisar de/ You will need / Usted necesitará



1 Pessoa
1 Person
1 Persona

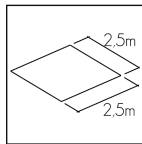

Espaço recomendado para montagem
Recommended space for assemble
Espacio recomendado para el armado

Ferramentas não inclusas
Tools not included / Herramientas no incluidas

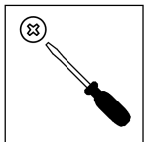

Chave Phillips
Screwdriver Phillips
Destornillador cruz

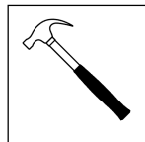

Martelo
Hammer
Martillo

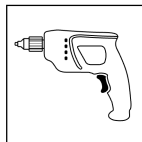

Furadeira
Drill machine
Taladro

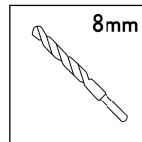









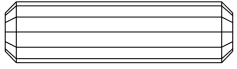
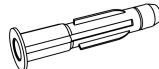
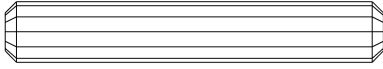
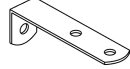

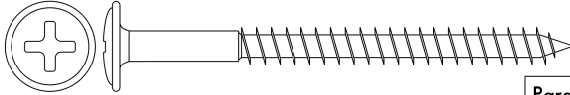

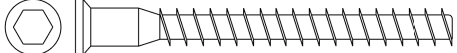

Broca
Drill bit
Taladro

* PESO EM KG/ Weight in Kg/ Peso en Kg
DIMENSÕES EM MM/ Dimensions in mm/ Dimensiones en mm

IDENTIFICAÇÃO DOS ACESSÓRIOS/ IDENTIFICATION OF ACCESSORIES/ IDENTIFICACIÓN DE ACCESORIOS

NOTAS: A separação dos acessórios antes de iniciar a montagem facilitará a mesma. Os parafusos e cavilhas estão na escala real. Em caso de dúvida na identificação, coloque o acessório sobre a imagem.
NOTES: The separation of the accessories before you start the assembly will facilitate the same. The screws and dowels are in real scale. In case of doubts about the identification, place the accessory on the image.
NOTAS: La separación de los accesorios antes de comenzar el armado facilitará el mismo. Los tornillos y taquetes son en escala real. En caso de dudas sobre la identificación, coloque el accesorio en la imagen.

A		Cavilha Wooden Dowel Pin	8x30 mm	22	P		Bucha expansiva Bushing Tapón	8x50 mm	01
B		Cavilha Wooden Dowel Pin	8x50 mm	02	Q		Suporte de metal Metalic bracket Soporte de metal	-	01
C		Haste minifix simples Simple minifix screw Tornillo minifix simple	-	02	R		Parafuso flangeado Flanged head screw Tornillo de cabeza flangeada	5,0x60 mm	01
D		Tambor minifix Drum lock Tambor minifix	12 mm	02					
E		Tapa furo adesivo Bore patch adhesive Tapones adhesivo	-	02					
F		Parafuso panela Pan head screw Tornillo de pan	3,5x14 mm	18					
G		Sapata redonda Small plastic foot Pie plástico	14 mm	06					
H		Parafuso estrutural Structural screw Tornillo estrutural	5,0x50 mm	10					
I		Tampa parafuso estrutural Structural screw cover Tapa tornillo estrutural	-	06					
J		Chave allen Allen key Llave Allen	-	01					
K		Dobradiça super alta Metal hinge super high Bisagra alta	26mm	04					
L		Calço dobradiça Hinge shim Bisagra de calce	-	04					
M		Passa fios Pass wires Pasar cables	46mm	01					
N		Garra de metal Metal claw Garra metal	-	04					
O		Prego Nail Clavo	10x10	35					

IDENTIFICAÇÃO DAS PEÇAS/ PARTS IDENTIFICATION/ IDENTIFICACIÓN DE LAS PIEZAS

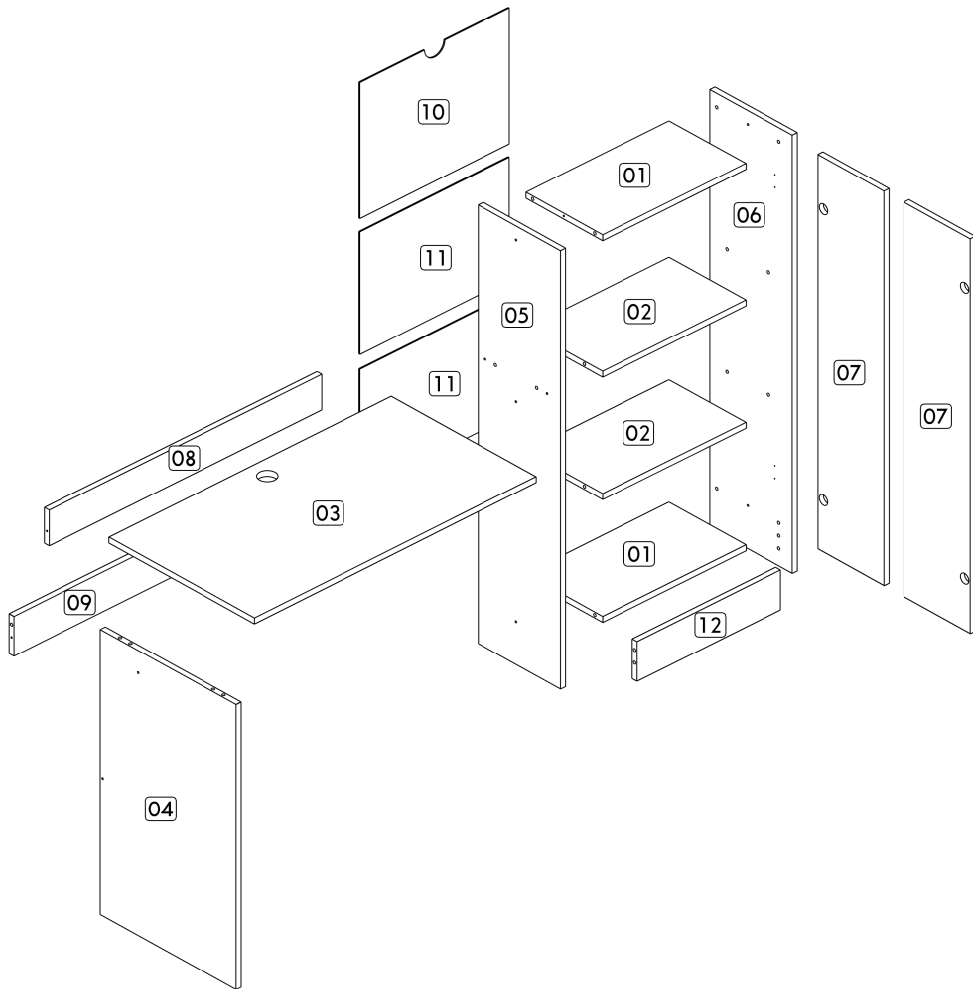

Nº	DESCRIÇÃO - DESCRIPTION - DESCRIPCIÓN	MEDIDAS-MEASURES - MEDIDAS (mm)	QTD.
01	Base - Base - Base	420 x 238 x 15	02
02	Prateleira - Shelf - Repisc	420 x 238 x 15	02
03	Tampo - Top - Tapa	830 x 450 x 15	01
04	Lateral mesa - Table side - Lateral mesa	715 x 420 x 15	01
05	Lateral esquerda - Left side - Lateral izquierda	1100 x 255 x 15	01
06	Lateral direita - Right side - Lateral derecha	1100 x 255 x 15	01
07	Porta - Door - Puerta	990 x 205 x 15	02
08	Travessa tampo - Top tray - Traviesa tapa	800 x 90 x 15	01
09	Travessa traseira - Rear tray - Traviesa trasera	800 x 100 x 15	01
10	Costa superior - Upper back - Fondo superior	440 x 342 x 03	01
11	Costa interna/ inferior - Bottom back - Fondo inferior	440 x 307 x 03	02
12	Rodapé - Footer - Rodapie	420 x 100 x 15	01

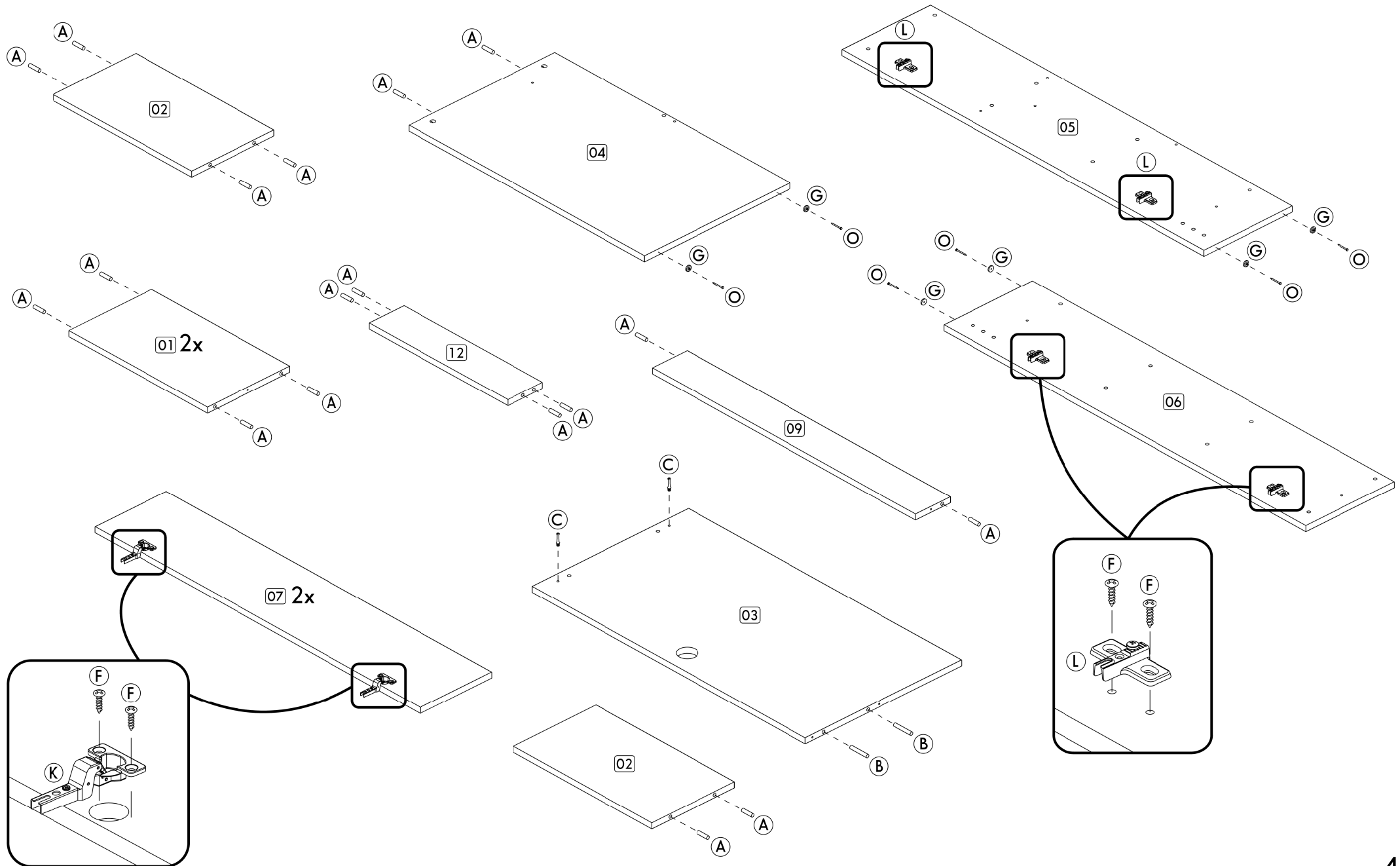

Passo/ Step/ Paso 01

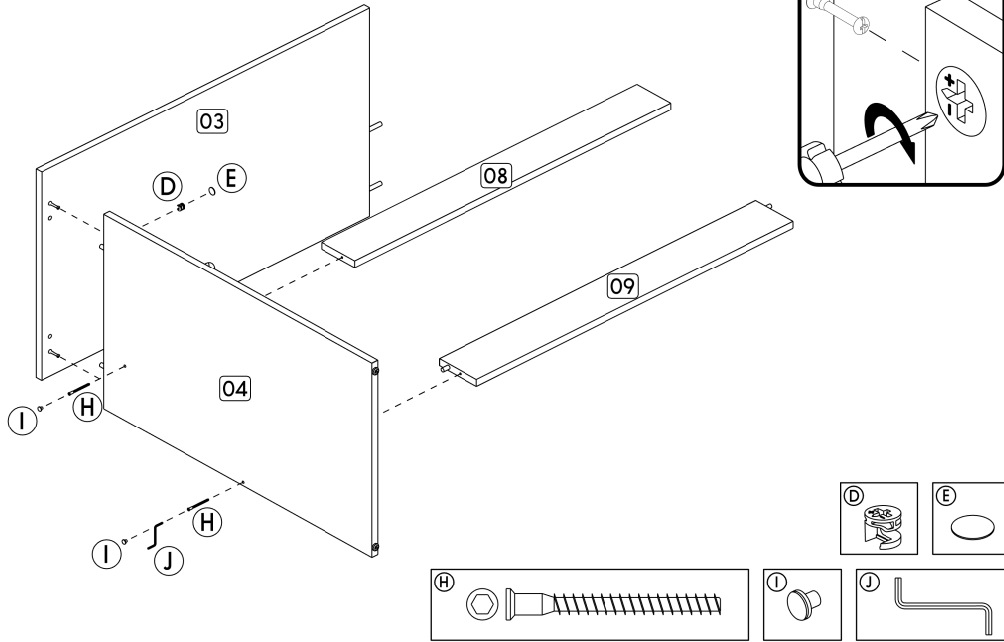

Passo/ Step/ Paso 02

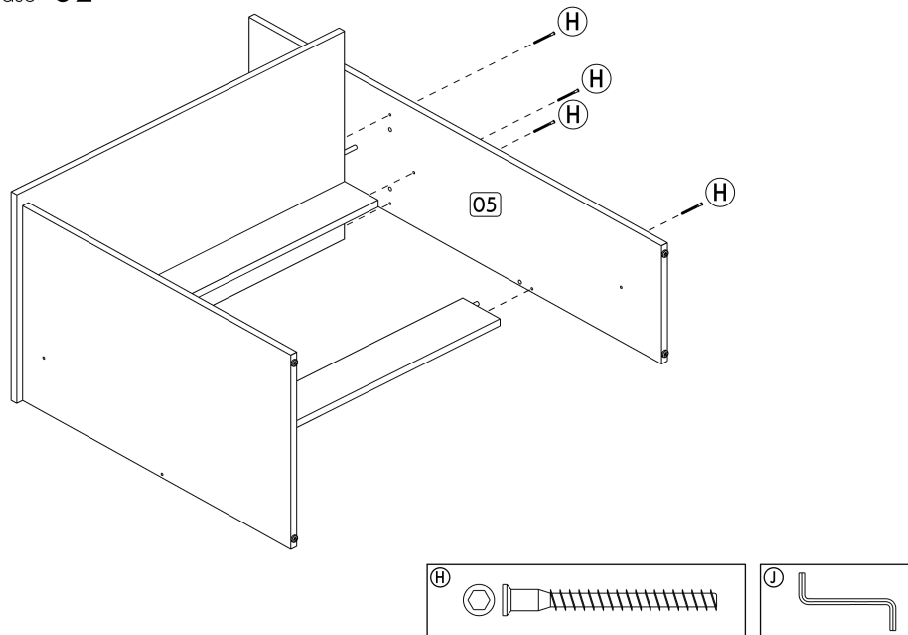

Passo/ Step/ Paso 03

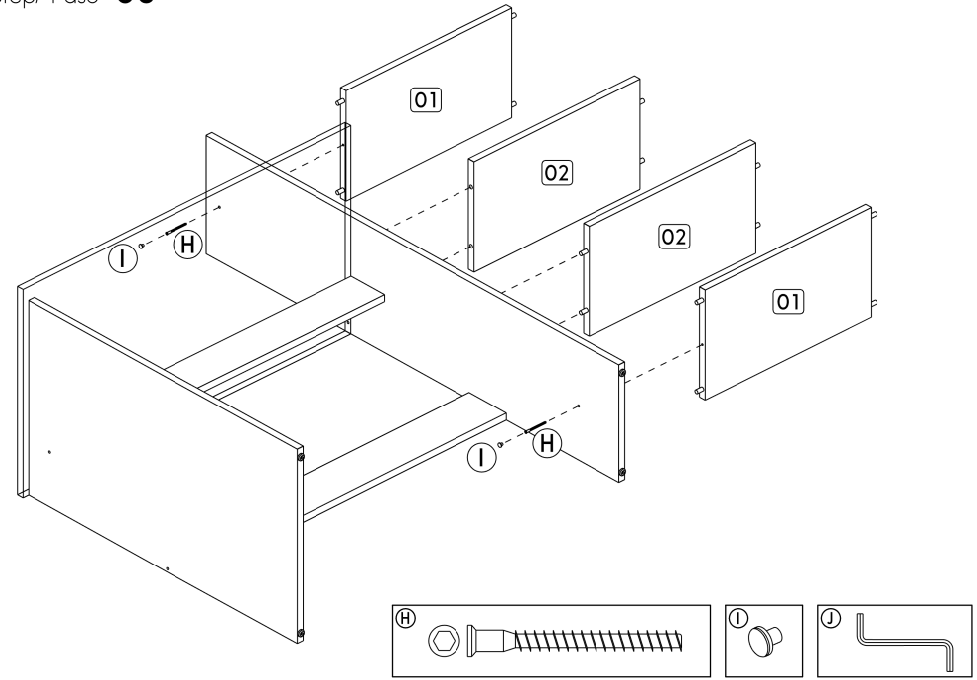

Passo/ Step/ Paso 04

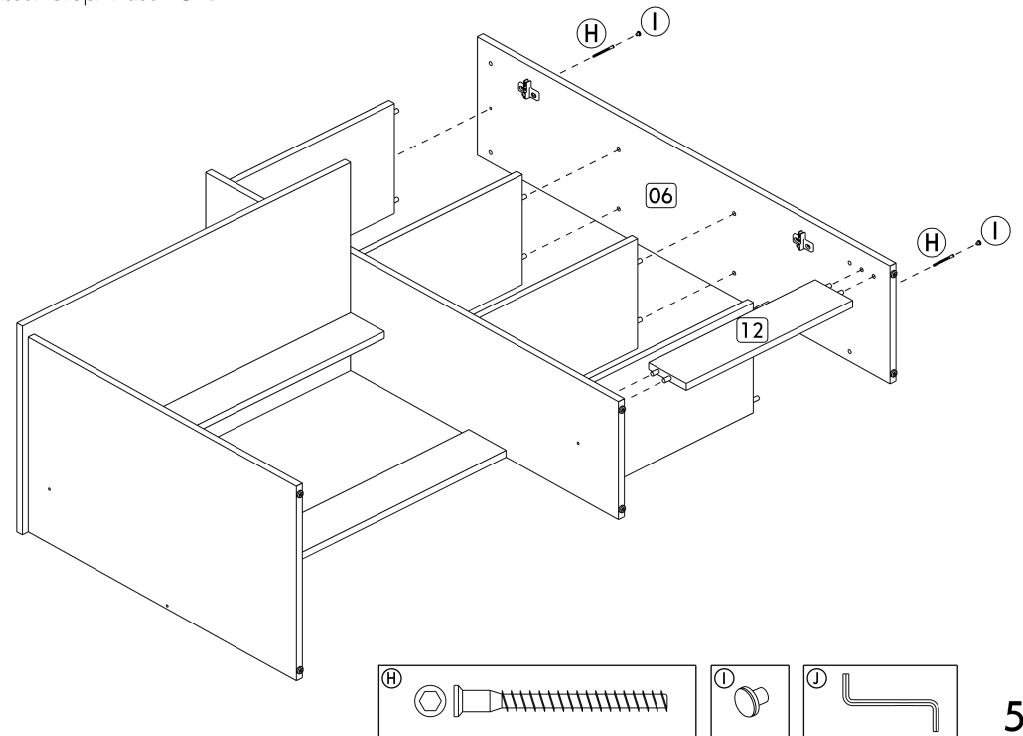

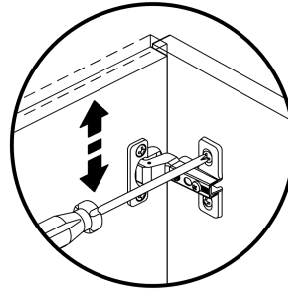
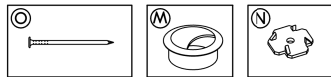
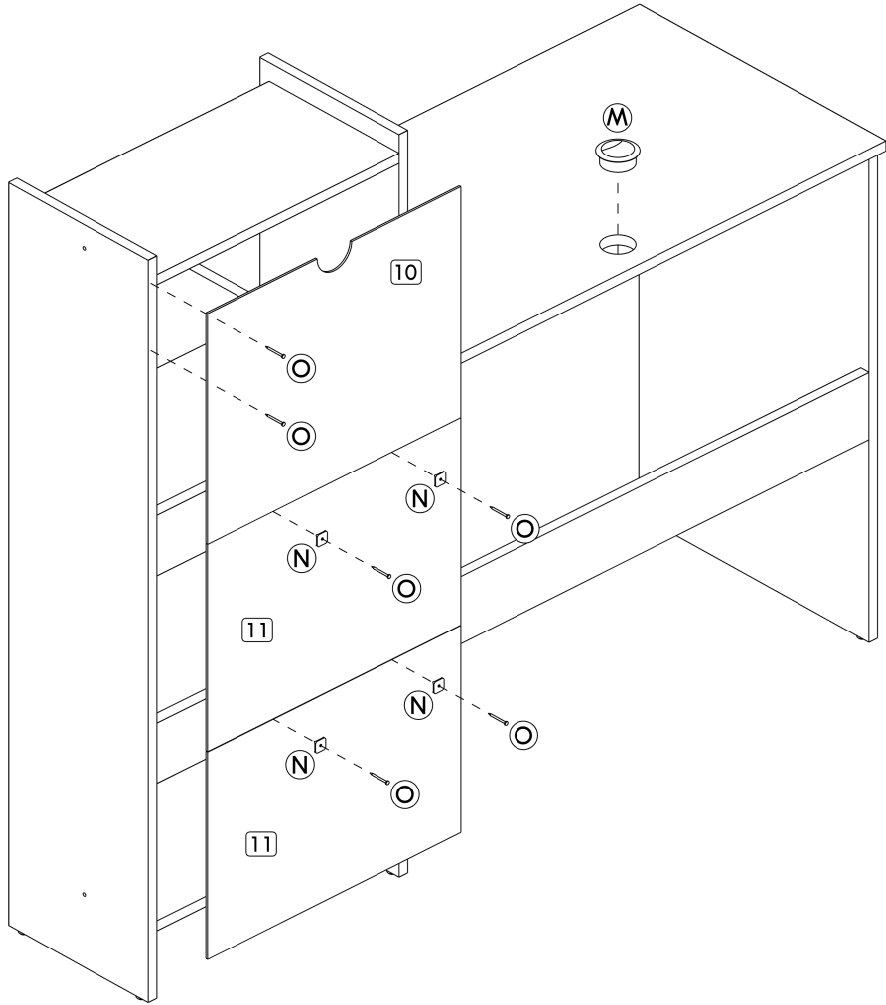

Regulagem Vertical
Ajuste Vertical
Vertical Adjustment

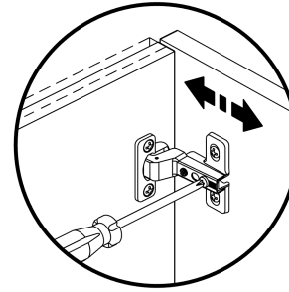

Regulagem Profundidade
Ajuste Profundidad
Depth Adjustment

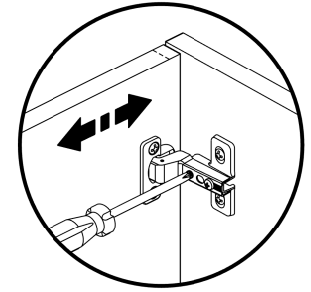

Regulagem Horizontal
Ajuste Horizontal
Horizontal Adjustment

