



**MANUAL DE MONTAGEM
ASSEMBLY INSTRUCTIONS
INSTRUCCIONES DE MONTAJE**

COD BR: BLC 62

Sumário Summary Resumen

Introdução Introduction Introducción	3
Antes de começar Before starting Antes de comenzar	4
Evite acidentes Avoid accidents Evitar accidentes	4
Dimensões e ferramentas Dimensions and tools Dimensiones y herramientas	5
Identificação das peças Identifying parts Identificación de las piezas	6
Acessórios incluídos na caixa Hardware included in box Accesorios incluidos en la caja	7
Montagem do móvel Furniture assembly Montaje del mueble	8

Introdução Introduction Introducción

Leia atentamente este manual e siga os passos indicados para que o produto não perca a garantia e também para uma perfeita montagem.

Read this manual and follow the steps in order to keep the guarantee and also for the perfect fit.

Lea este manual y siga los pasos para que el producto no pierda la garantía y también para el ajuste perfecto.

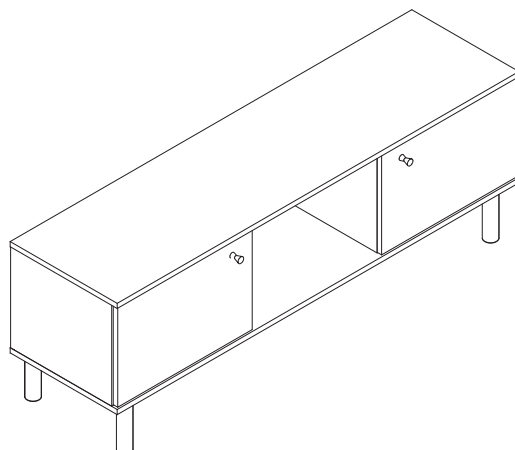

Antes de começar Before starting Antes de comenzar

Antes de começar a montagem prepare o ambiente, deixando-o completamente limpo e com bom espaço para iniciar o trabalho.

Prepare the room before starting the assembly, leaving it completely clean and the area in good condition to start the work.

Antes de comenzar el montaje preparar el ambiente, dejándolo completamente limpio y con bueno espacio para comenzar el trabajo.

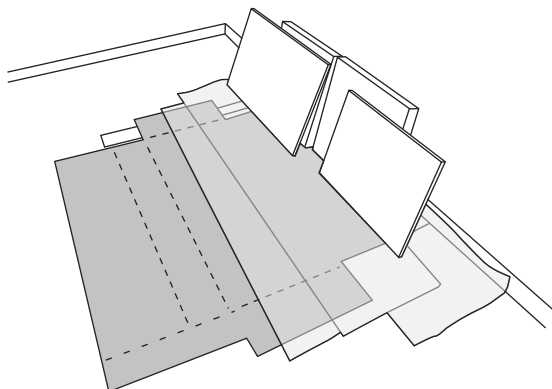

Utilize o papelão da própria embalagem para separar e apoiar as peças retiradas das caixas.

Use the cardboard of the packaging to separate and support the parts removed from the boxes.

Utilice el cartón de la embalaje para separar y apoyar las piezas desmontadas de las cajas.

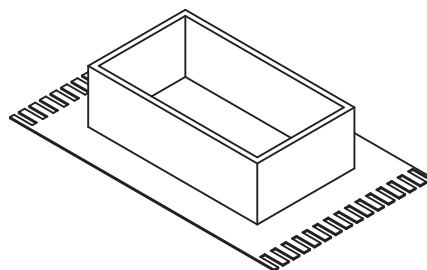

Forre a área de montagem com um cobertor ou tapete. Assim, você evita avarias nas peças durante o processo de montagem.

Cover the assembly area with a blanket or carpet to avoid damaging the parts during the assembly process.

Cubrir la zona de ensamble con una manta o alfombra. De este modo, se evitan daños en las piezas durante el proceso de montaje.



Evite acidentes Avoid accidents Prevenir accidentes

Solicitamos observar atentamente as orientações de montagem como: fixação do produto na parede, colocação de cola em locais específicos necessários, o peso suportado pelo produto, etc...

We request you to carefully observe the assembly instructions as: fixing the product on the wall, adding glue in needed and specific places, product weight limit, etc.

Pedimos que lea atentamente las instrucciones, principalmente las informaciones de fijación del producto en la pared, colocación de pegamento en local específico y necesario, el peso soportado por el producto etc...

Não escale ou se apoie no móvel.

Do not climb or lean on the furniture.

No se suba ni se apoye en el mueble.

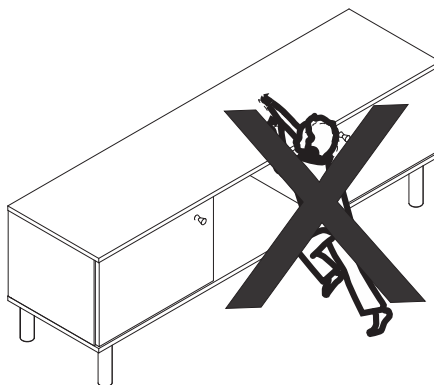

Dimensões e ferramentas
Dimensions and tools
Dimensiones y herramientas

Dimensões:

L: 1350 A: 474 P: 360 mm

Dimensions:

W: 53.14 H: 18.66 D: 14.17 inches

Dimensiones:

L: 1350 A: 474 P: 360 mm

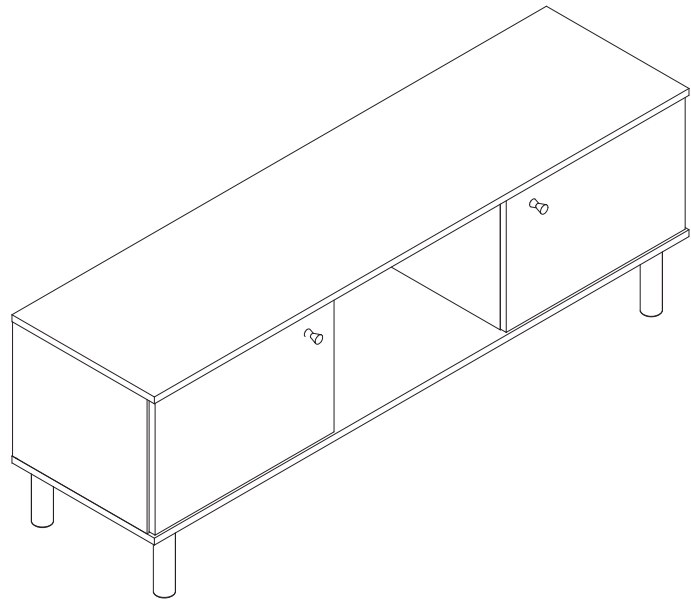

Limpeza
Cleaning
Limpieza

Pano levemente umedecido com água, seguido de pano seco, não utilizar produtos químicos ou abrasivos.
You can clean the product with slightly dampened cloth followed by a dry cloth. Do not use chemicals or abrasives.
Solamente utilizar un paño húmedo y después un paño seco, no utilice productos químicos o abrasivos.

Todas as peças do móvel foram marcadas com um número. Antes de começar a montagem, identifique as peças numeradas em relação às instruções de montagem. Uma vez concluída a montagem, os números podem ser facilmente removidos com um pano ligeiramente embebido em álcool. Use álcool apenas para remover números das peças.

All the furniture parts have been marked with a number. Before you start assembling, please identify the numbered parts in relation to the assembly instructions. Once assembly is completed, the numbers can be easily removed with a cloth slightly dampened in alcohol. Use alcohol only to remove part numbers.

Todos las piezas del mueble fueron marcadas con un número. Antes de empezar el montaje, identifique las piezas numeradas en relación con las instrucciones de montaje. Una vez que se completa el armado, los números se pueden quitar fácilmente con un paño ligeramente empapado en alcohol. Use alcohol solo para eliminar números de las piezas.

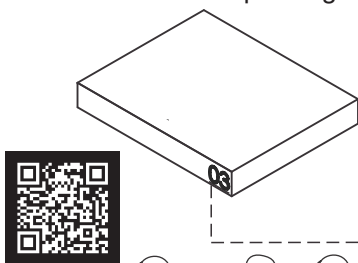

UTILIZE ALCOOL APENAS PARA REMOVER O NUMERO DAS PEÇAS
USE ALCOHOL ONLY TO REMOVE PART NUMBERS
UTILICE ALCOHOL SOLAMENTE PARA ELIMINAR EL NUMERO DE LAS PIEZAS

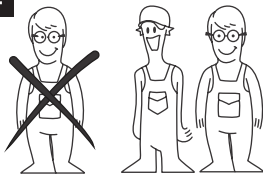

Para facilitar a montagem, utilize uma parafusadeira elétrica.
To speed assembly, use an electronic screwdriver.
Para facilitar el armado, utilice un destornillador eléctrico.

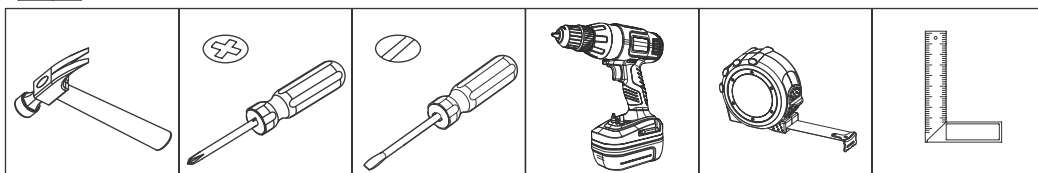

COD BR: BLC 62

PEÇA	DESCRIÇÃO	QUANT.
001	BASE	1
002	TAMPO	1
003	LATERAL ESQUERDA	1
004	LATERAL DIREITA	1
005	DIVISÓRIA ESQUERDA	1
006	DIVISÓRIA DIREITA	1
007	PRATELEIRA	2
008	PORTA ESQUERDA	1
009	PORTA DIREITA	1
010	COSTA	1
011	PÉS	4

PART	DESCRIPTION	QTY
001	BASE	1
002	TOP	1
003	LEFT SIDE	1
004	RIGHT SIDE	1
005	LEFT PARTITION	1
006	RIGHT PARTITION	1
007	SHELF	2
008	LEFT DOOR	1
009	RIGHT DOOR	1
010	BACK	1
011	FEET	4

PIEZA	DESCRIPCIÓN	CANTIDAD
001	BASE	1
002	TAPA	1
003	LATERAL IZQUIERDA	1
004	LATERAL DERECHA	1
005	PARTICIÓN IZQUIERDA	1
006	PARTICIÓN DERECHA	1
007	REPISA	2
008	PUERTA IZQUIERDA	1
009	PUERTA DERECHA	1
010	REVÉS	1
011	PIES	4

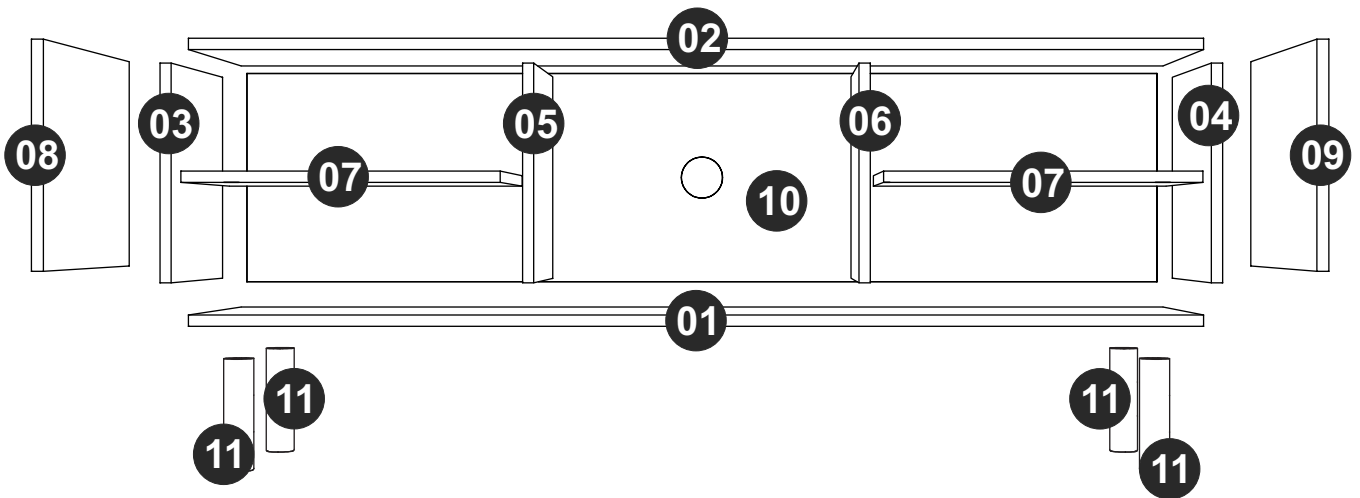

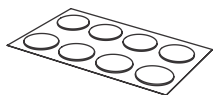

TAPA FUROS x 04
STICKER x 04
TAPAS PLÁSTICAS x 04



EF 000033x 16
8x30



EF 000106 X 16
3,5x14 CC

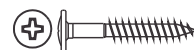

EF 000113 x02
3,5X30 CF



EF 000745 x 04
5X40



CLICK-A - 8



CLICK-B - 8

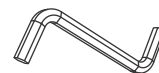

EF 000741 x 01



PUXADOR x 2
HANDLE x 2
MANIJA x 2



EF 000024 X 4

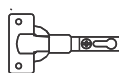

EF 000044 X 4

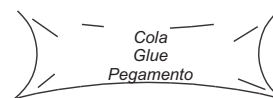

EF 000748 x 01

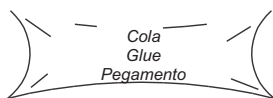

EF 000008 x 01



GIZ x 01
CHALK x 01
TIZA x 01

Utilize para medir as ferragens.

Utilice para medir el herraje.

Use for measuring the hardware.

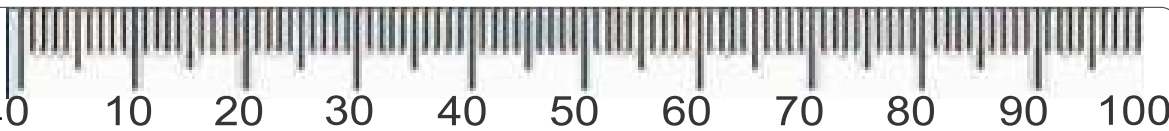

Garantia (exclusivo para o Brasil/exclusivo de Brasil/exclusive to Brazil):

A garantia dos produtos fabricados pela BRV Móveis, abrange eventuais defeitos-vícios de fabricação, no prazo estabelecido pelo código de Defesa do Consumidor, em seu artigo 26.II. o qual prevê a garantia de 90 (noventa) dias.

A = 17KG - 37.47 LB

B = 5KG - 11.02 LB

C = 4KG - 8.81 LB

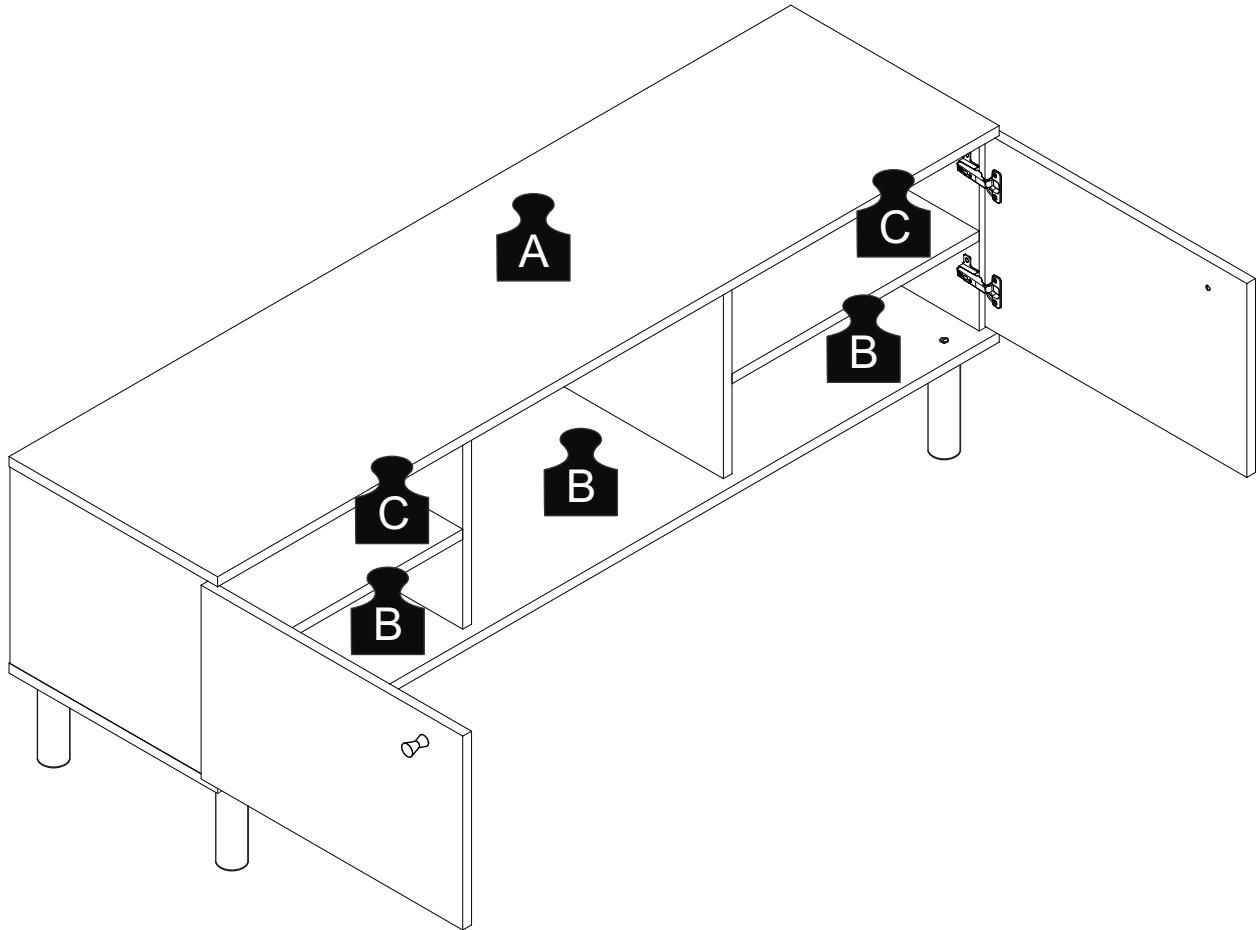

PASSO 1 / STEP 1 / PASO 1

Insira os clicks-A nas peças 01 e 02.
Insert the clicks-A into pieces 01 and 02.
Añade los clicks-A en las piezas 01 y 02.

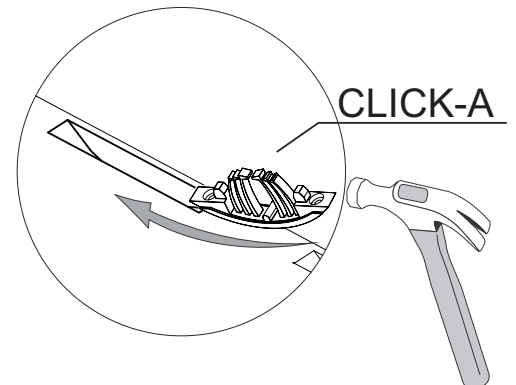
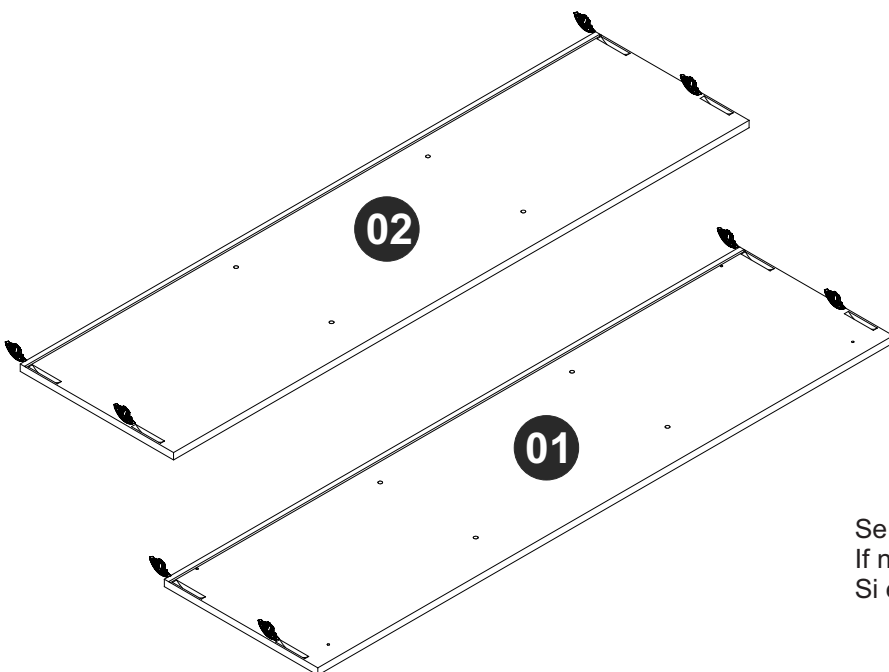

Se necessário, use o martelo para auxiliar.
If necessary use the hammer to help.
Si es necesario utilice el martillo para ayudar.

PASSO 2 / STEP 2 / PASO 2

Insira os clicks-B nas peças 03 e 04.
Insert the clicks-B into pieces 03 and 04.
Añade los clicks-B en las piezas 03 y 04.

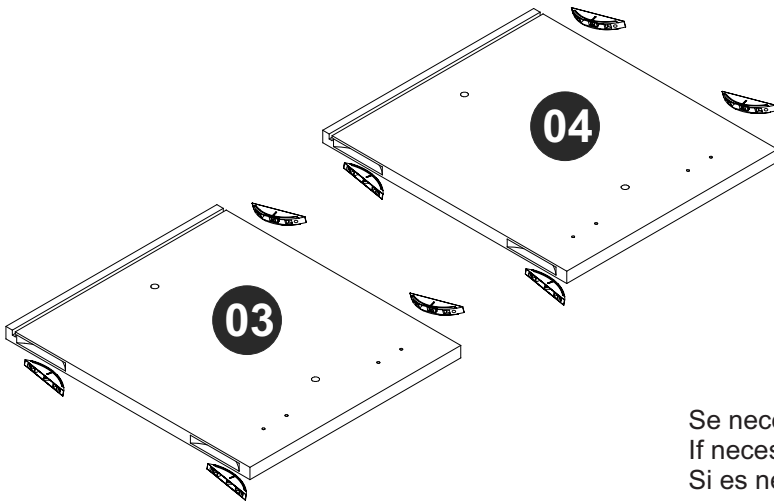

CLICK-B

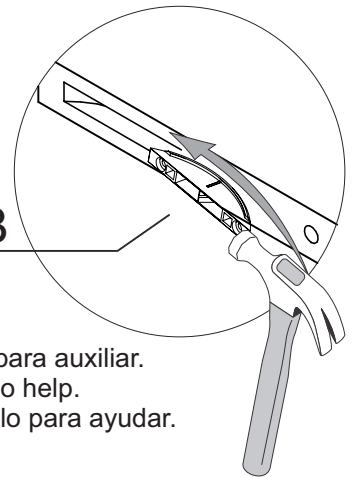

Se necessário, use o martelo para auxiliar.
If necessary use the hammer to help.
Si es necesario utilice el martillo para ayudar.

PASSO 3 / STEP 3 / PASO 3

Fixe a ferragem EF 000024 usando a ferragem EF 000106.
Fix hardware EF 000024 using hardware EF 000106.
Fije el herraje EF 000024 utilizando el herraje EF 000106.

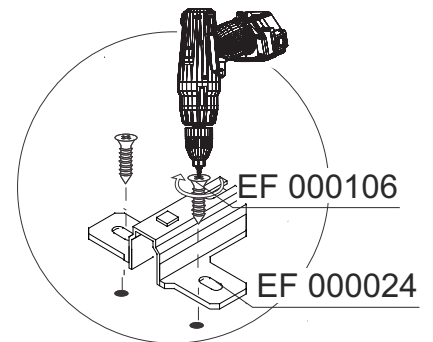
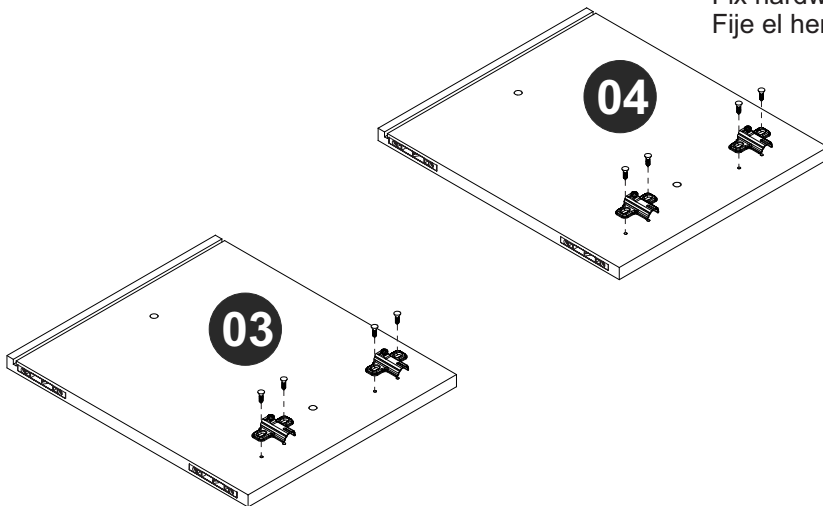

PASSO 4 / STEP 4 / PASO 4

Utilize a cola antes de inserir a ferragem EF 000033 nas peças 05, 06 e 07.
Use the glue before connecting hardware EF 000033 into pieces 05, 06 and 07.
Utilice el pegamento antes de insertar herraje EF 000033 en las piezas 05, 06 y 07.

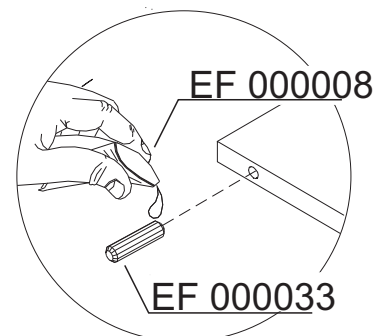
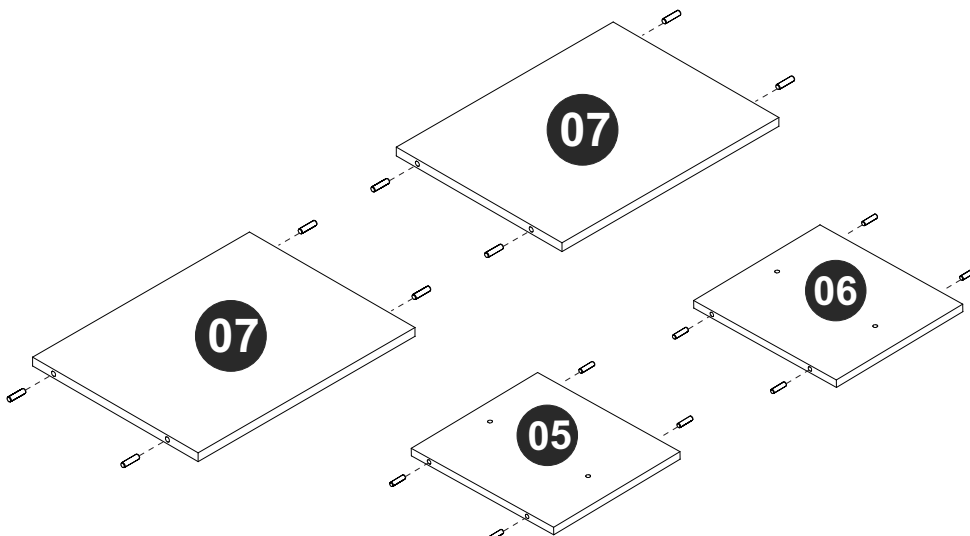

PASSO 5 / STEP 5 / PASO 5

Fixe o puxador usando a ferragem EF 000113. Fixe a ferragem EF 000044 usando a ferragem EF 000106.
Fix the handle using hardware EF 000113. Fix hardware EF 000044 using hardware EF 000106.
Fije la manija utilizando el herraje EF 000113. Fije el herraje EF 000044 utilizando el herraje EF 000106.

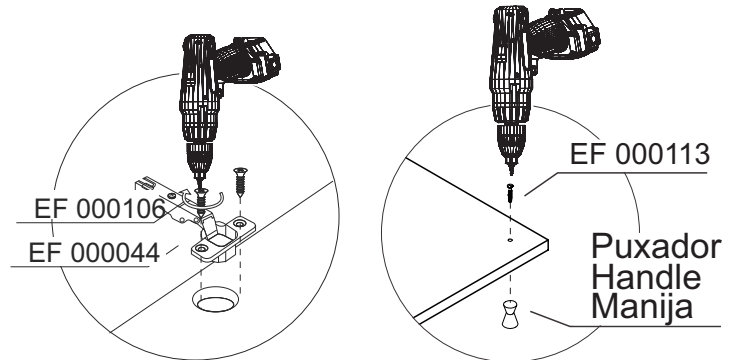
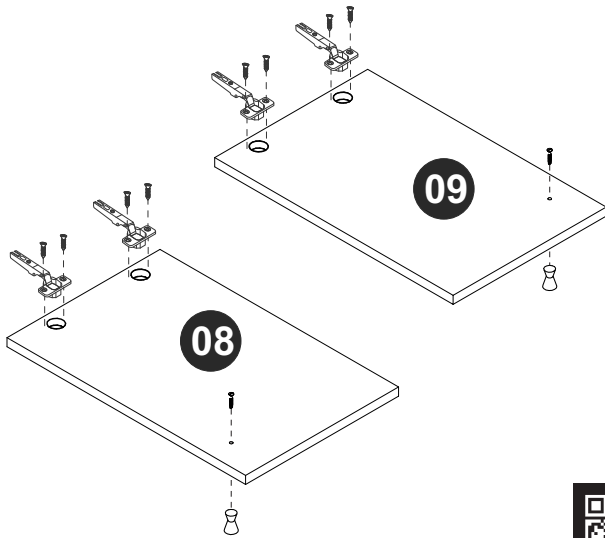

PASSO 6 / STEP 6 / PASO 6

Utilize a cola antes de conectar as peças 04, 06 e 07 .
Use the glue before connecting pieces 04, 06 and 07 .
Utilice el pegamento antes de juntar las piezas 04, 06 y 07.

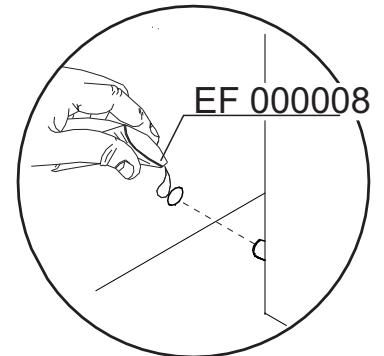
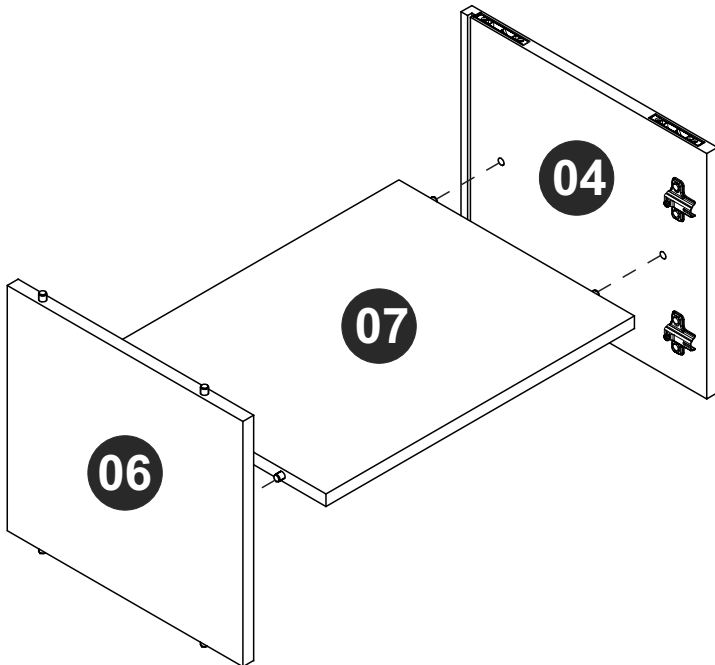

PASSO 7 / STEP 7 / PASO 7

Utilize a cola antes de conectar as peças 03, 05 e 07 .
Use the glue before connecting pieces 03, 05 and 07 .
Utilice el pegamento antes de juntar las piezas 03, 05 y 07.

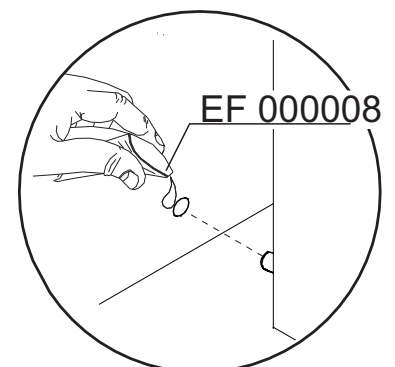
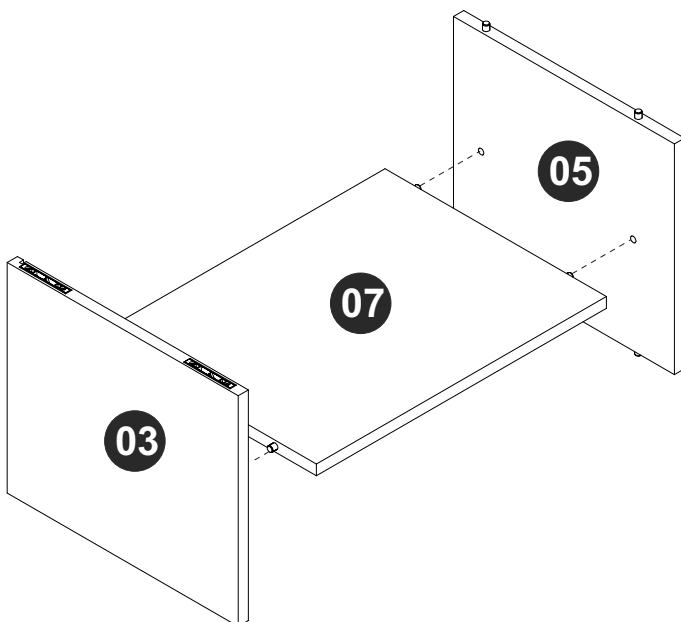

PASSO 8 / STEP 8 / PASO 8

Fixe os pés (peças 11) à peça 01 utilizando a ferragem EF 000745 e EF 000741.
Fix the feet (pieces 11) to piece 01 using hardware EF 000745 and EF 000741.
Fije los pies (piezas 11) en la pieza 01 utilizando los herrajes EF 000745 y EF 000741.

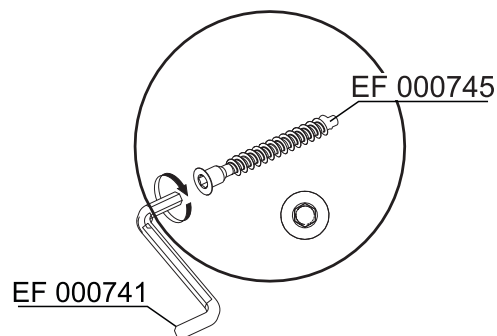
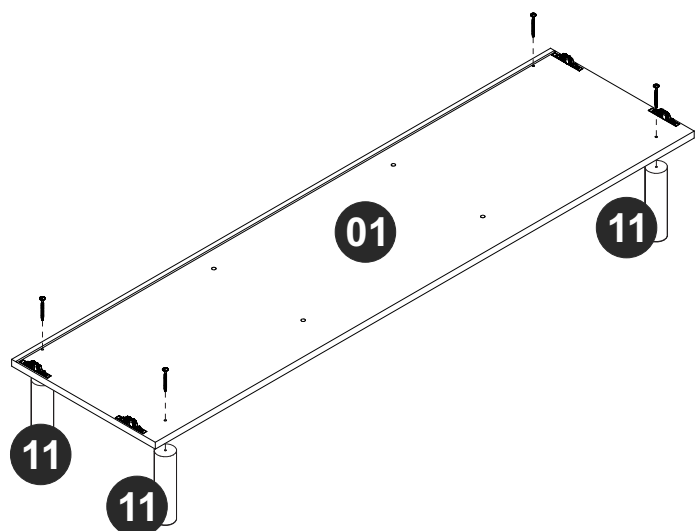

PASSO 9 / STEP 9 / PASO 9

Utilize a cola (EF 000748) antes de conectar a peça 01 à parte montada no passo anterior, encaixando os clicks-A e os clicks-B.
Use the glue (EF 000748) before connecting piece 01 at part assembled on previous step, fitting the clicks-A and clicks-B.
Utilice el pegamento (EF 000748) antes de juntar la pieza 01 a la parte armada en el paso anterior, encajando los clicks-A y los clicks-B.

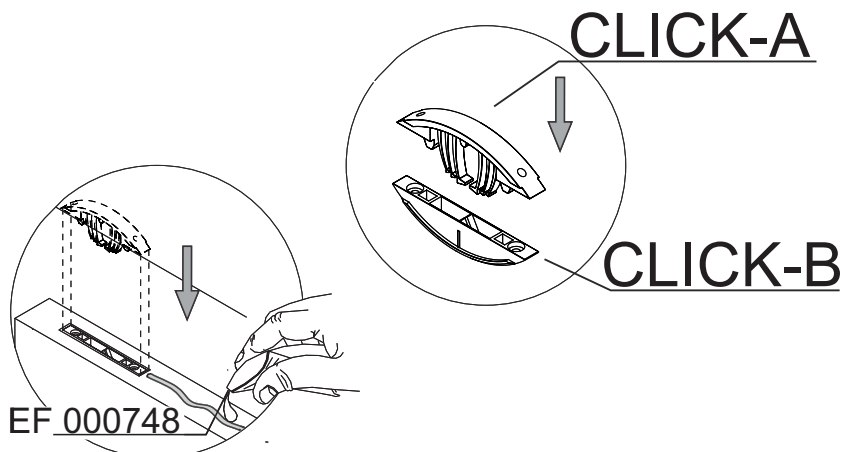
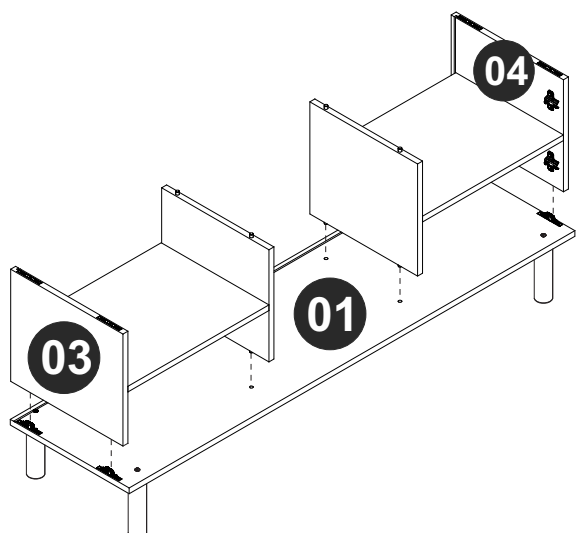

PASSO 10 / STEP 10 / PASO 10

Encaixe a peça 10 entre os espaços específicos nas peças 03 e 04.
Fix piece 10 at part assembled through the specific spaces in pieces 03 and 04.
Fije la pieza 10 entre los espacios específicos en las piezas 03 y 04.

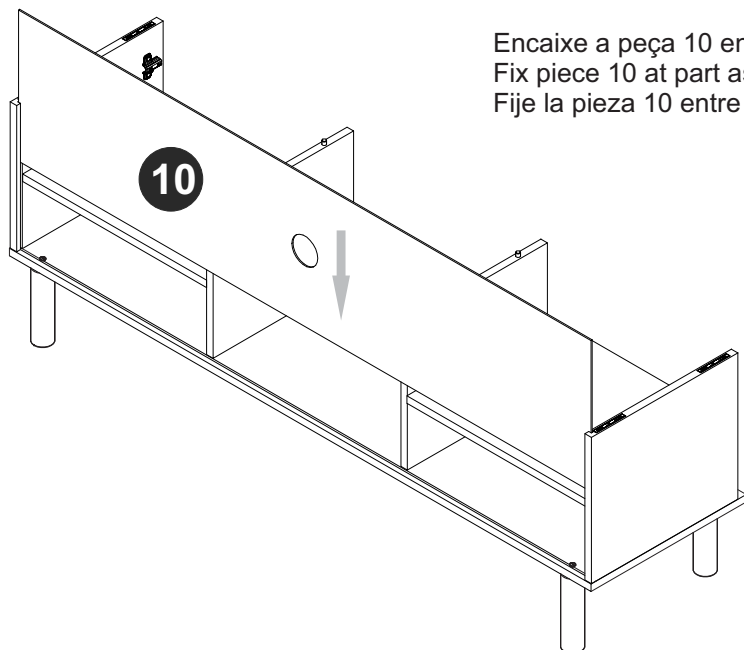

PASSO 11 / STEP 11 / PASO 11

Utilize a cola (EF 000748) antes de conectar a peça 02 a parte montada no passo anterior, encaixando os clicks-A e os clicks-B.

Use the glue (EF 000748) before connecting piece 02 at part assembled on previous step, fitting the clicks-A and clicks-B.

Utilice el pegamento (EF 000748) antes de juntar la pieza 02 a la parte armada en el paso anterior, encajando los clicks-A y los clicks-B.

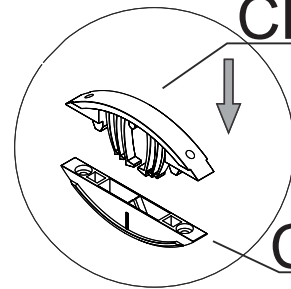
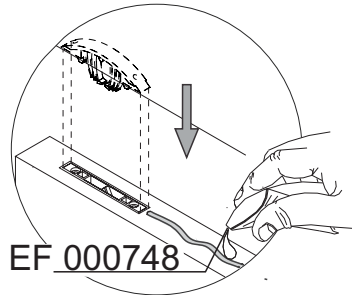
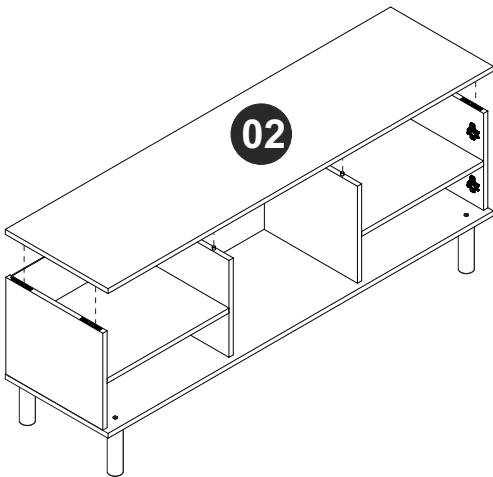

CLICK-A

CLICK-B

PASSO 12 / STEP 12 / PASO 12

Fixe as peças 08 e 09 ao móvel montado.

Attach pieces 08 and 09 at the assembled furniture.

Fije las piezas 08 y 09 al mueble armado.

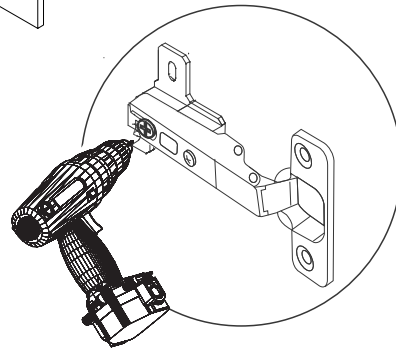
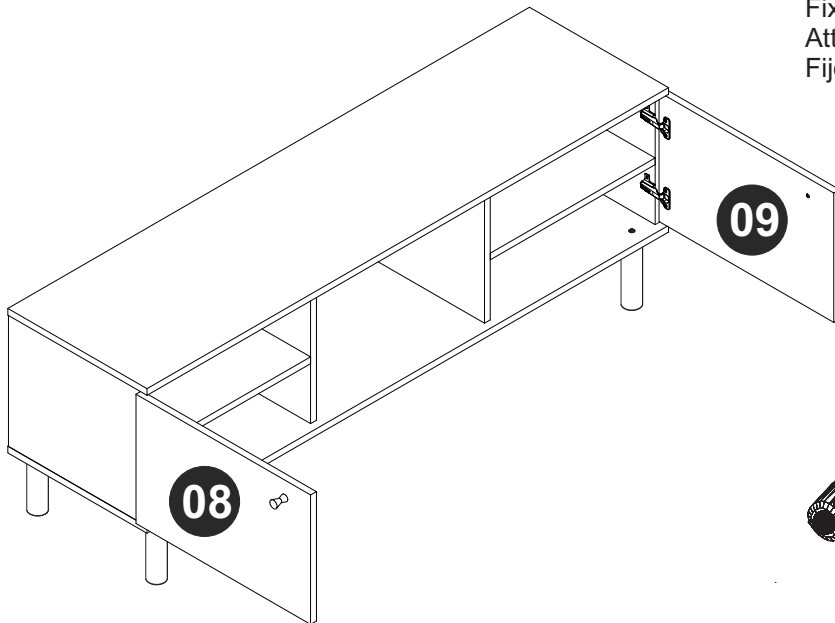

PASSO 13 / STEP 13 / PASO 13

Use o giz para dar o acabamento final ao produto.

Use os tapa furos para cobrir os parafusos aparentes.

Use the chalk to give the final finish on the product.

Use stickers to cover apparent screws.

Utilice la tiza para dar el acabado final al producto.

Utilice los tapa huecos para cubrir los tornillos aparentes.

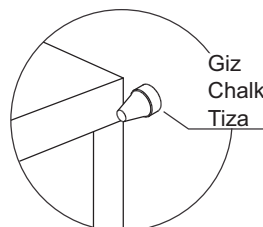
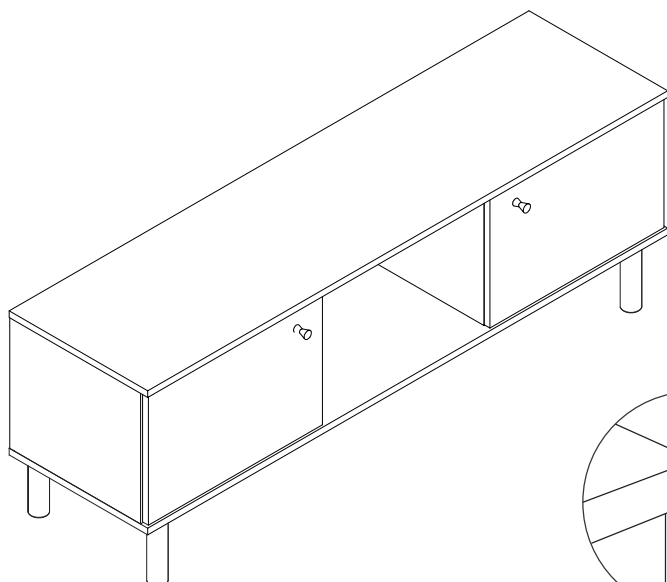

Giz
Chalk
Tiza

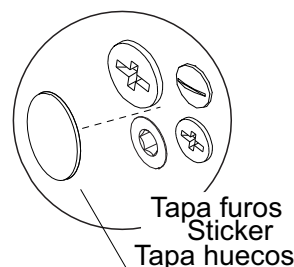

Tapa furos
Sticker
Tapa huecos

