

ASSEMBLY INSTRUCTIONS MANUAL DE MONTAGEM / INSTRUCCIONES DE ARMADO

MADRI KITCHEN 9 DOORS 1 DRAWER
COZINHA 9 PORTAS 1 GAVETA MADRI
COCINA 9 PUERTAS 1 CAJÓN MADRI

Reference
Referència
Referencia **230193**

Revisé
Revisão
Revisión **00**



ENGLISH
PORTUGUÊS
ESPAÑOL

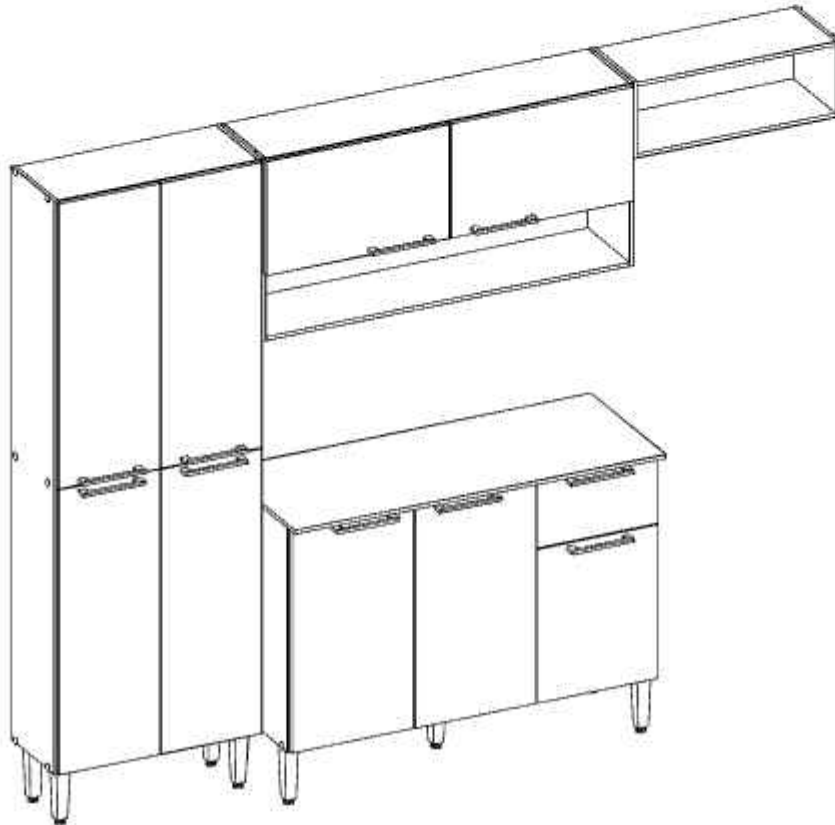

MAXIMUM RECOMMENDED WEIGHT
BEING THIS EVENLY DISTRIBUTED.

PESO MÁXIMO RECOMENDADO SIENDO
ESTE DISTRIBUIDO UNIFORMEMENTE.

PESO MÁXIMO RECOMENDADO SIENDO
ESTE UNIFORMEMENTE DISTRIBUIDO.

	LB	KG
C	6	3
D	11	5
F	22	10
H	44	20

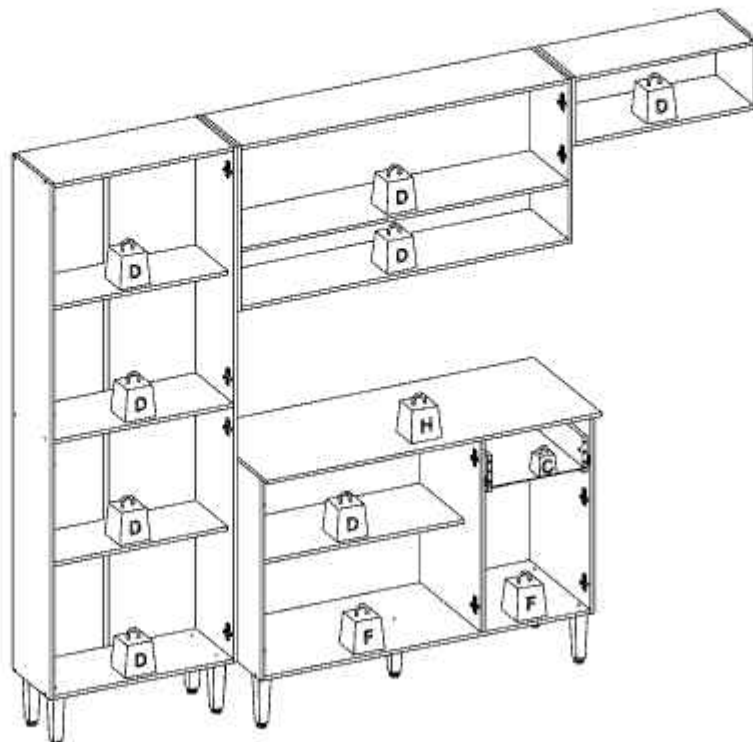

Nº	Measures Inches	Medidas cm	Qty./Qtd.
01	43 1/4 x 17 1/2 x 1/2	109.8 x 44.5 x 1.2	1
02	28 x 11 3/8 x 1/2	71.2 x 29.0 x 1.2	1
03	42 1/4 x 15 3/4 x 1/2	107.2 x 40.0 x 1.2	1
04	25 5/8 x 15 3/4 x 1/2	65.0 x 40.0 x 1.2	1
05	25 1/8 x 15 3/4 x 1/2	63.8 x 40.0 x 1.2	1
06	25 5/8 x 15 3/4 x 1/2	65.0 x 40.0 x 1.2	1
07	7 5/8 x 14 1/8 x 5/8	19.5 x 35.8 x 1.5	1
08	9 7/8 x 23 x 1/2	25.0 x 58.5 x 1.2	1
09	11 3/4 x 4 1/2 x 5/8	29.9 x 11.5 x 1.5	1
10	13 7/8 x 12 3/8 x 1/8	35.4 x 31.3 x 0.3	1
11	42 3/8 x 9 7/8 x 1/2	107.6 x 25.0 x 1.2	1
12	9 7/8 x 23 1/4 x 1/2	25.0 x 59.1 x 1.2	1
13	42 3/8 x 9 7/8 x 1/2	107.6 x 25.0 x 1.2	1
14	42 3/8 x 9 7/8 x 1/2	107.6 x 25.0 x 1.2	1
15	20 7/8 x 9 7/8 x 1/2	53.0 x 25.0 x 1.2	1
16	20 7/8 x 9 7/8 x 1/2	53.0 x 25.0 x 1.2	1
17	43 1/8 x 13 1/8 x 1/8	109.6 x 33.3 x 0.3	1
18	9 7/8 x 23 x 1/2	25.0 x 58.5 x 1.2	1
19	8 5/8 x 9 7/8 x 1/2	22.0 x 25.0 x 1.2	1
20	8 5/8 x 9 7/8 x 1/2	22.0 x 25.0 x 1.2	1
21	9 7/8 x 23 1/4 x 1/2	25.0 x 59.1 x 1.2	1
22	9 7/8 x 23 1/4 x 1/2	25.0 x 59.1 x 1.2	1
23	9 3/8 x 23 1/4 x 1/2	21.2 x 59.1 x 1.2	2
24	65 3/8 x 9 7/8 x 1/2	166.0 x 25.0 x 1.2	1
25	65 3/8 x 9 7/8 x 1/2	166.0 x 25.0 x 1.2	1
26	43 1/8 x 7 1/2 x 1/8	109.6 x 19.2 x 0.3	1
27	25 3/4 x 14 3/8 x 1/8	65.5 x 36.4 x 0.3	1
28	32 1/2 x 11 7/8 x 1/8	82.7 x 30.2 x 0.3	4
29	28 5/8 x 12 7/8 x 1/8	72.5 x 32.7 x 0.3	2
30	32 1/2 x 11 3/4 x 5/8	82.6 x 29.9 x 1.5	1
31	32 1/2 x 11 3/4 x 5/8	82.6 x 29.9 x 1.5	1
32	32 1/2 x 11 3/4 x 5/8	82.6 x 29.9 x 1.5	1
33	32 1/2 x 11 3/4 x 5/8	82.6 x 29.9 x 1.5	1
34	25 3/8 x 14 1/8 x 5/8	64.4 x 35.9 x 1.5	1
35	25 3/8 x 14 1/8 x 5/8	64.4 x 35.9 x 1.5	1
36	21 1/4 x 13 x 5/8	54.1 x 33.1 x 1.5	1
37	21 1/4 x 13 x 5/8	54.1 x 33.1 x 1.5	1
38	17 1/2 x 14 1/8 x 5/8	44.6 x 35.8 x 1.5	1
96	14 x 4 1/2 x 5/8	35.5 x 11.5 x 1.5	1
97	14 x 4 1/2 x 5/8	35.5 x 11.5 x 1.5	1

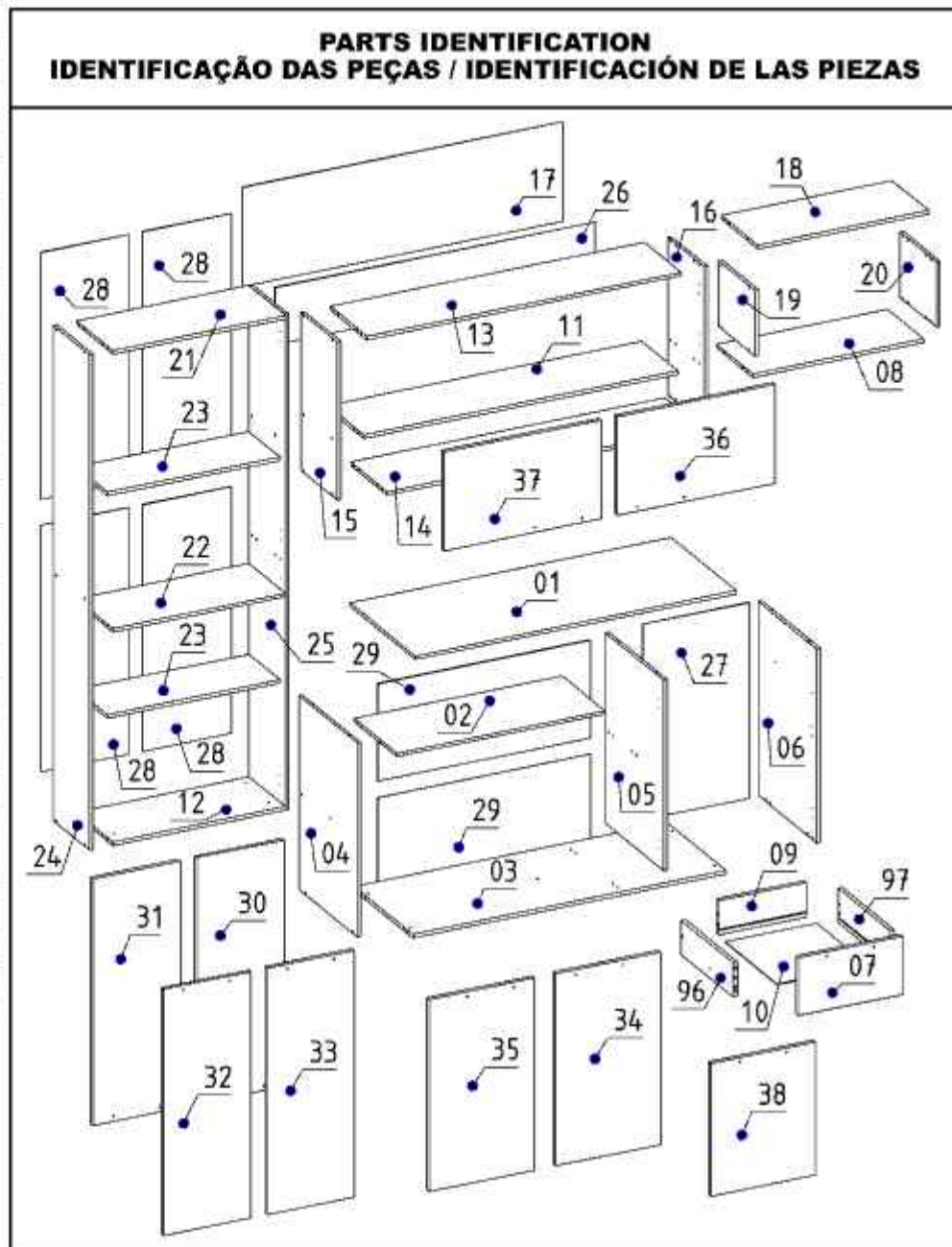

YOU WILL NEED / VOCÊ VAI PRECISAR DE / USTED NECESITARÁ

Tools not supplied / Ferramentas não fornecidas / Herramientas no incluidas

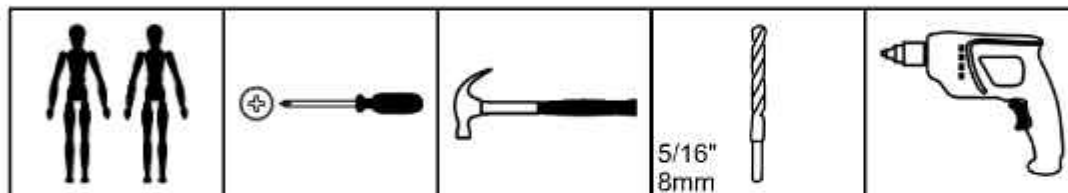

2 People
2 Pessoas
2 Personas

Screwdriver Phillips
Chave Phillips
Destornillador cruz

Hammer
Martelo
Martillo

5/16"
8mm
Drill bit
Broca
Taladro

Drill machine
Furadeira
Taladro











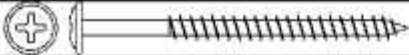



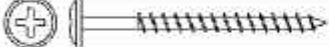





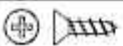

The separation of the accessories before you start the assembly will facilitate the same. In case of doubt on the size of the screws and bolts, use the ruler to bottom of page 3.

A separação dos acessórios antes de iniciar a montagem facilitará a mesma. Em caso de dúvida no tamanho dos parafusos e cavilhas, utilize a régua ao final da página 3.

La separación de los accesorios antes de comenzar el armado facilitará el mismo. En caso de duda sobre el tamaño de los tornillos y taquetes, utilice la regla al pie de página 3.

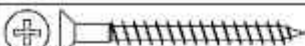
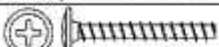
IDENTIFICATION OF ACCESSORIES IDENTIFICAÇÃO DOS ACESSÓRIOS/ IDENTIFICACIÓN DE ACCESORIOS

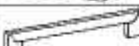
A		Flanged head screw / Parafuso flangeado / Tornillo de cabeza flangeada	5,0x60 mm	9
A1		Glue / Cola / Pegamento	13 g	1
A4		Metallic bracket / Cantoneira de metal / Suporte de metal	22x22 mm	6
A6		"H" profile / Perfil "H" / Perfil "H"	-	2
B3		Bushing / Bucha expansiva / Tapón	8x50 mm	9
C		Flanged head screw / Parafuso flangeado / Tornillo de cabeza flangeada	4,5x45 mm	9
C1		Metal claw / Garra de metal / Garra metal	-	21
D5		Hinge shim / Calço dobradiça / Bisagra de calce	-	18
E		Wooden dowel / Cavilha / Taquete	8x30 mm	6
E3		Shelf bracket / Suporte de prateleira / Suporte de repisa	8x7 mm	8
F1		Wooden dowel / Cavilha / Taquete	6x30 mm	48
F6		Metal hinge curve / Dobradiça curva / Esquina de bisagra metálica	26 mm	18
J		Simple minifix screw / Haste minifix simples / Tornillo minifix simple	-	2
L		Drum lock / Tambor minifix / Tambor minifix	12 mm	2
L9		Flat head screw / Parafuso chato / Tornillo de cabeza plana	3,5x12 mm	110
L17		Telescopic slide / Corrediça telescópica / Corredera telescópica	350 mm	2
M		Bore patch adhesive / Tapa furo adesivo / Tapones adhesivo	-	42
N		Nail / Prego / Clavo	10x10	142
N5		Support "L" / Suporte "L" / Soporte "L"	-	9
N6		Cover / Capa / Cubierta	-	6
O		Flat head screw / Parafuso chato / Tornillo de cabeza plana	4,5x45 mm	44
T		Flanged head screw / Parafuso flangeado / Tornillo de cabeza flangeada	3,5x25 mm	20
X15		Foot / Pé Cônico FP / Pie	170 mm	9
Z14		Handle / Puxador Napoli / Tirador	160 mm	10



PRE-ASSEMBLE
PRÉ-MONTAGE / PRE ARMADO

01

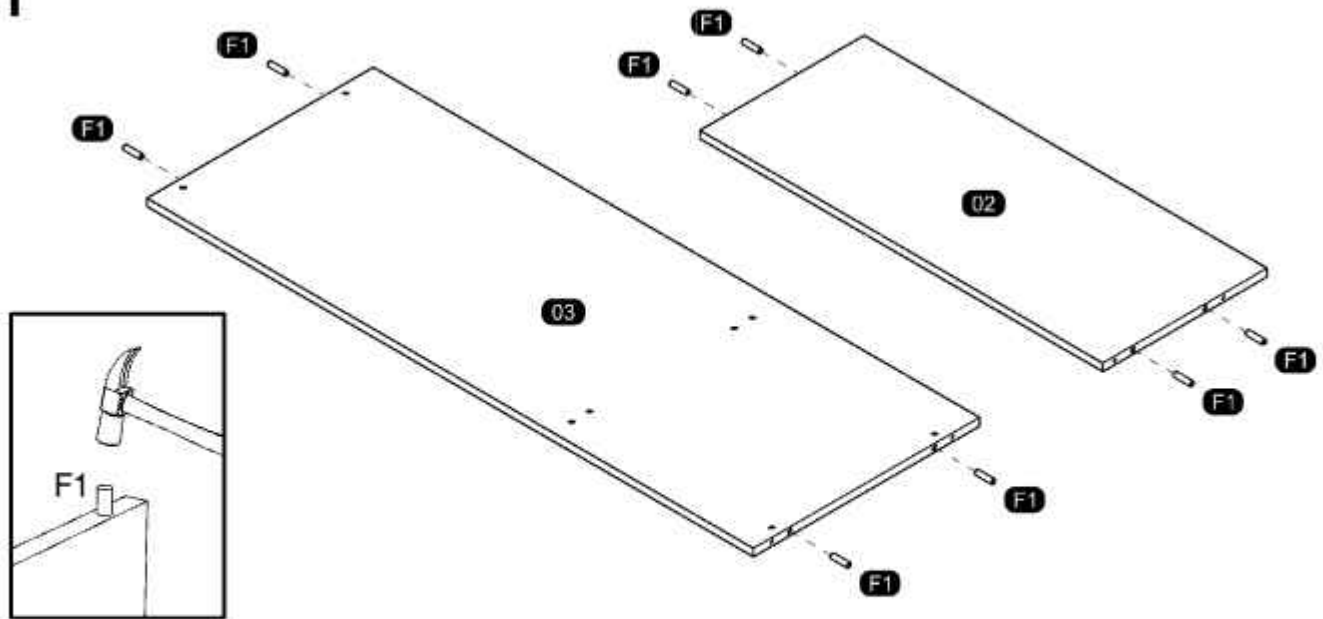

02

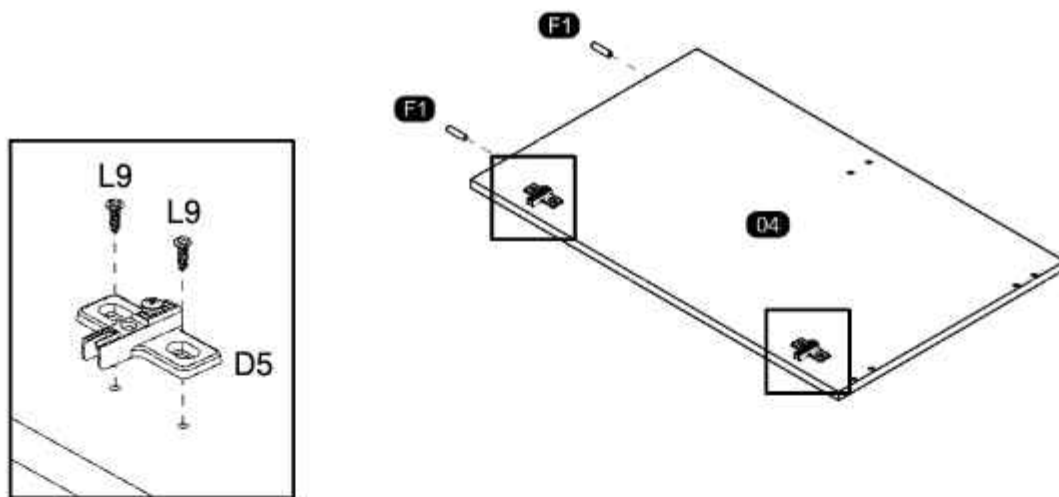

03

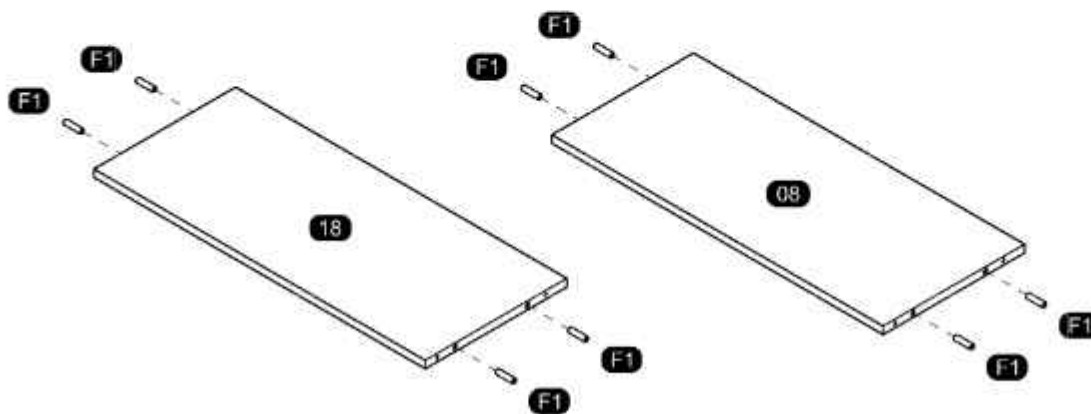

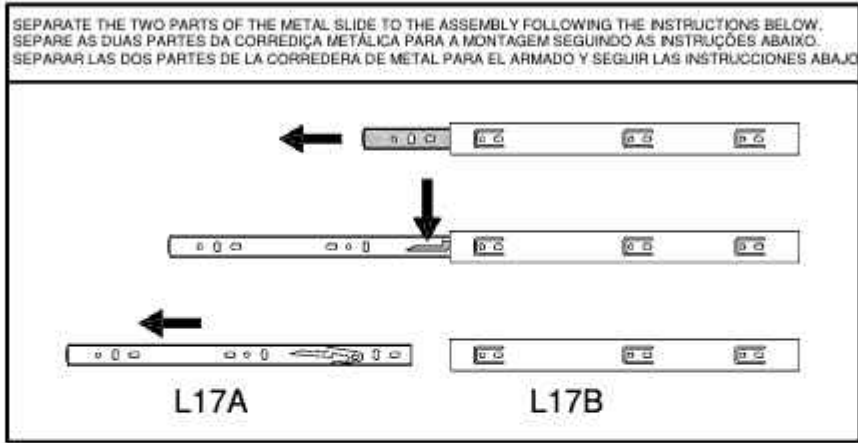

05

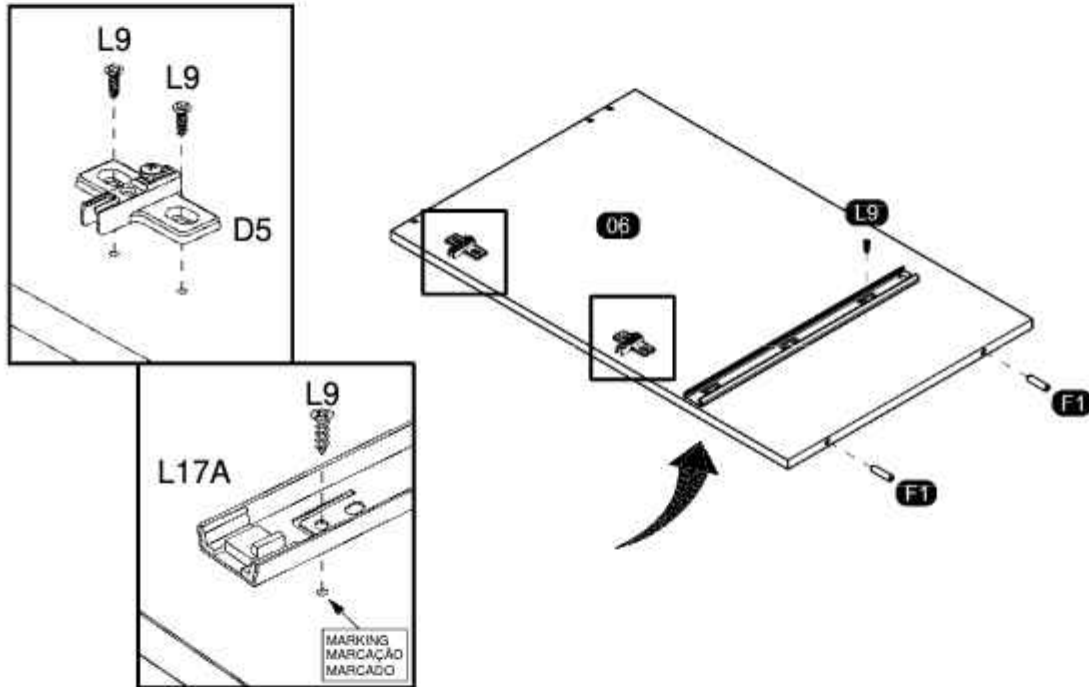

06

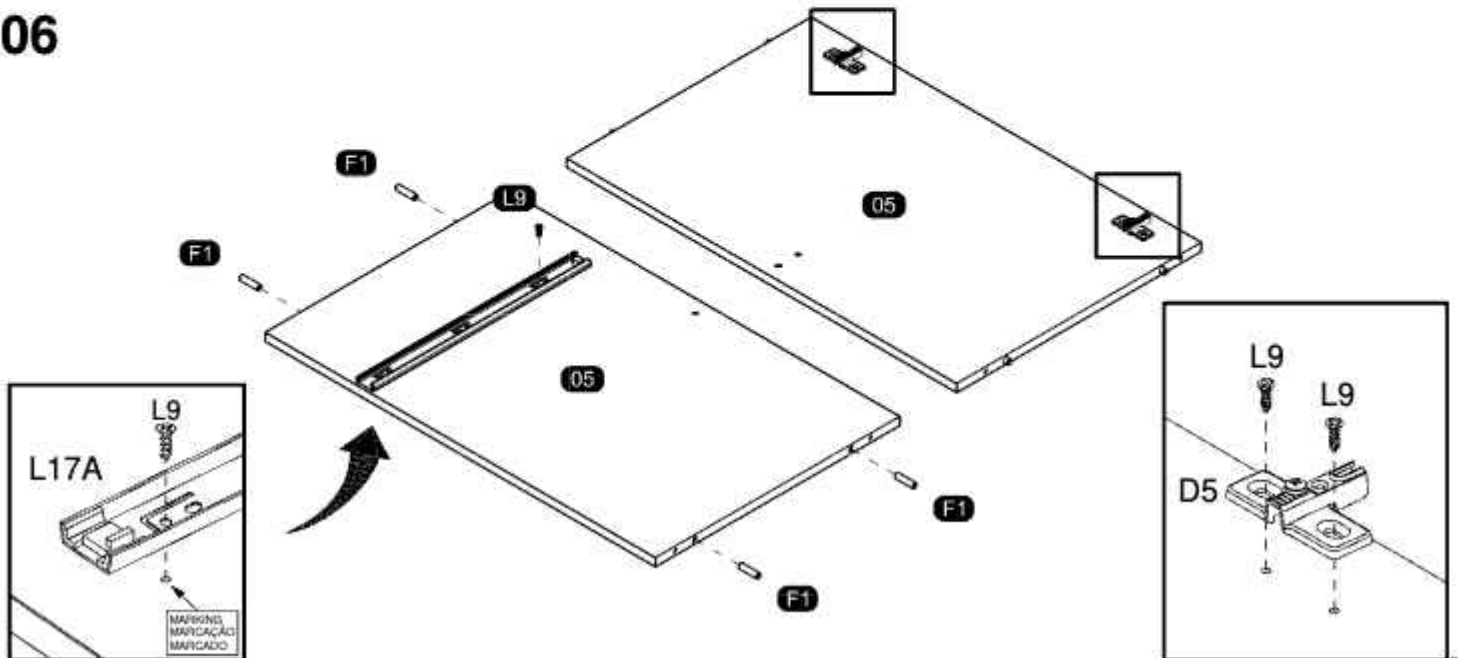

07

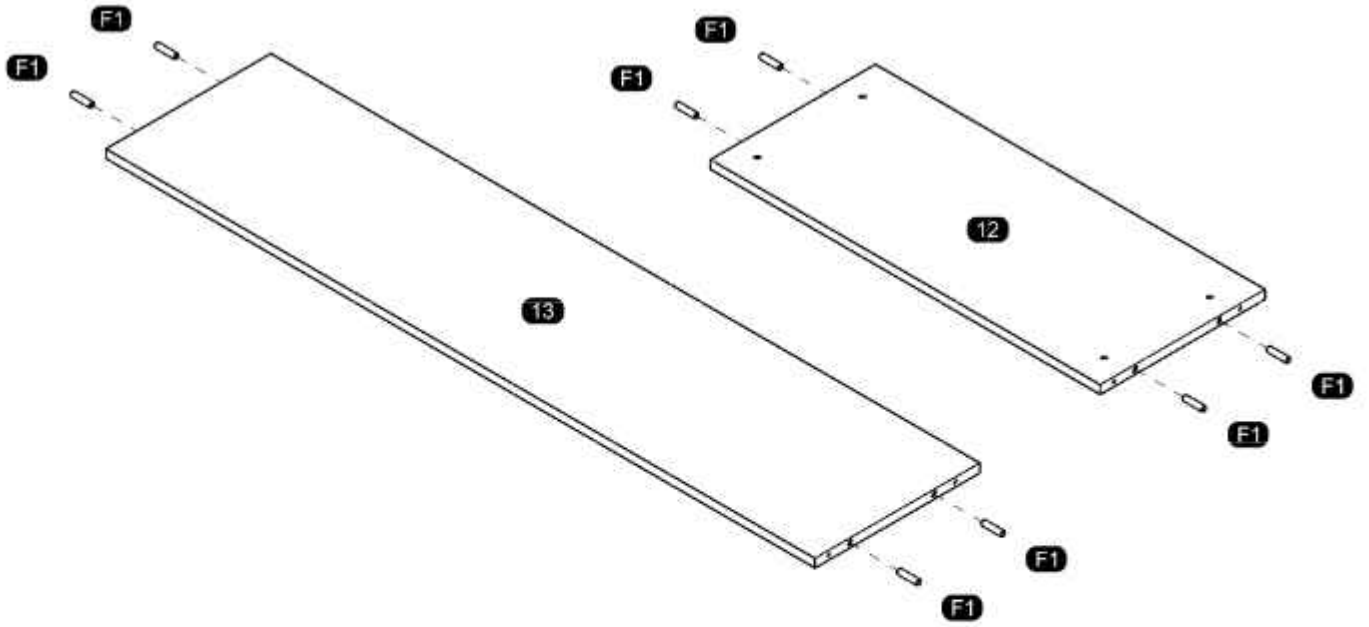

08

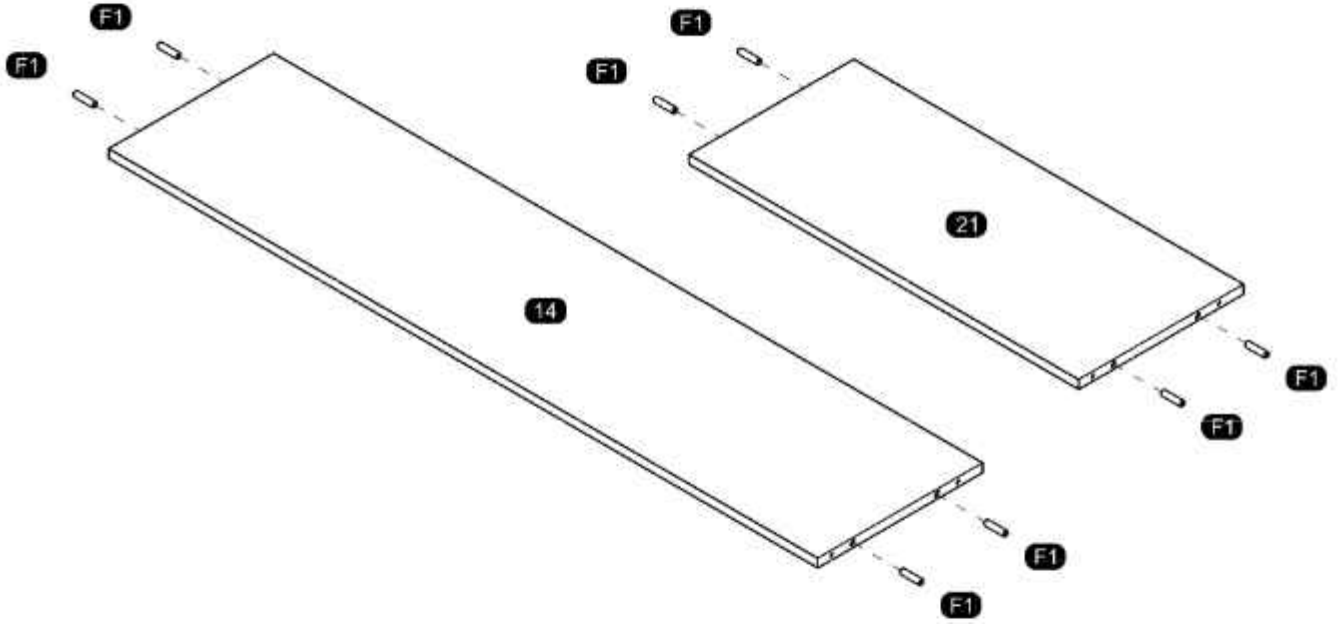

09

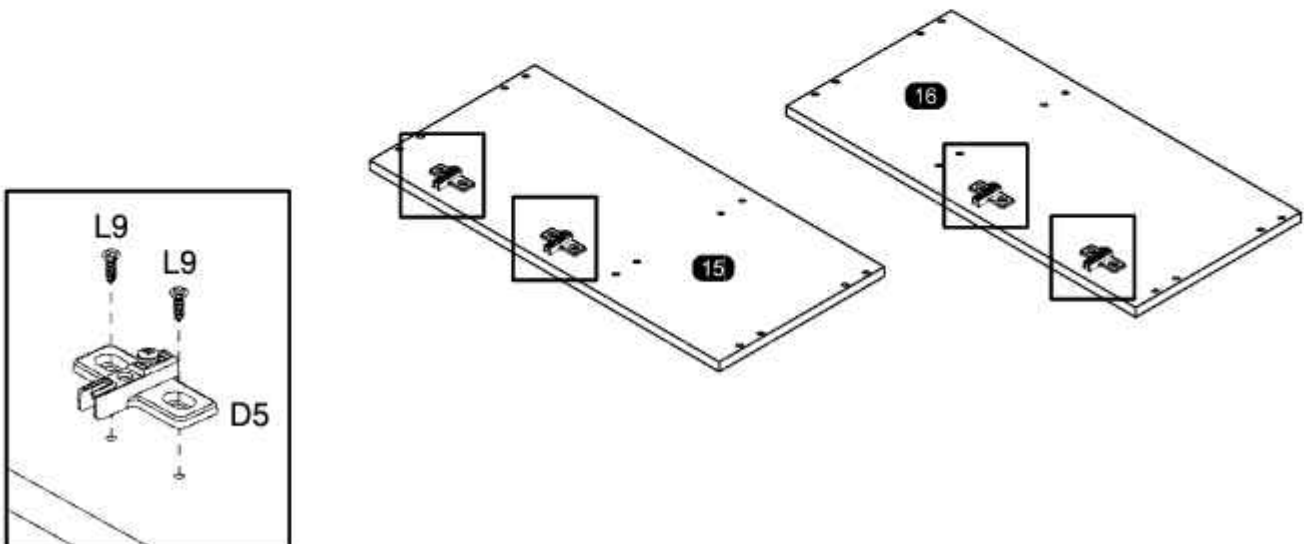

10

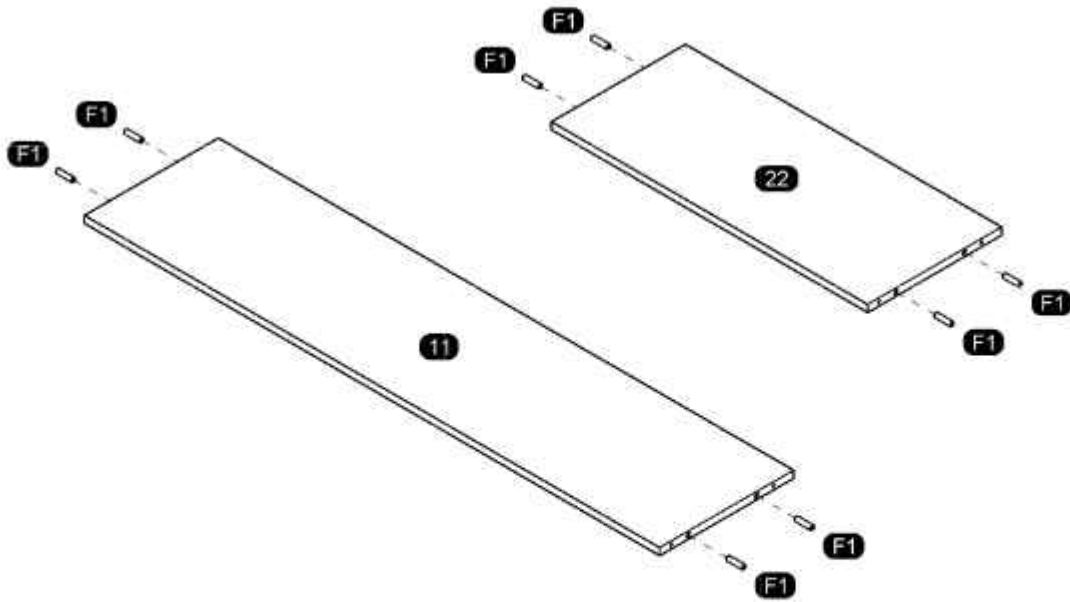

11

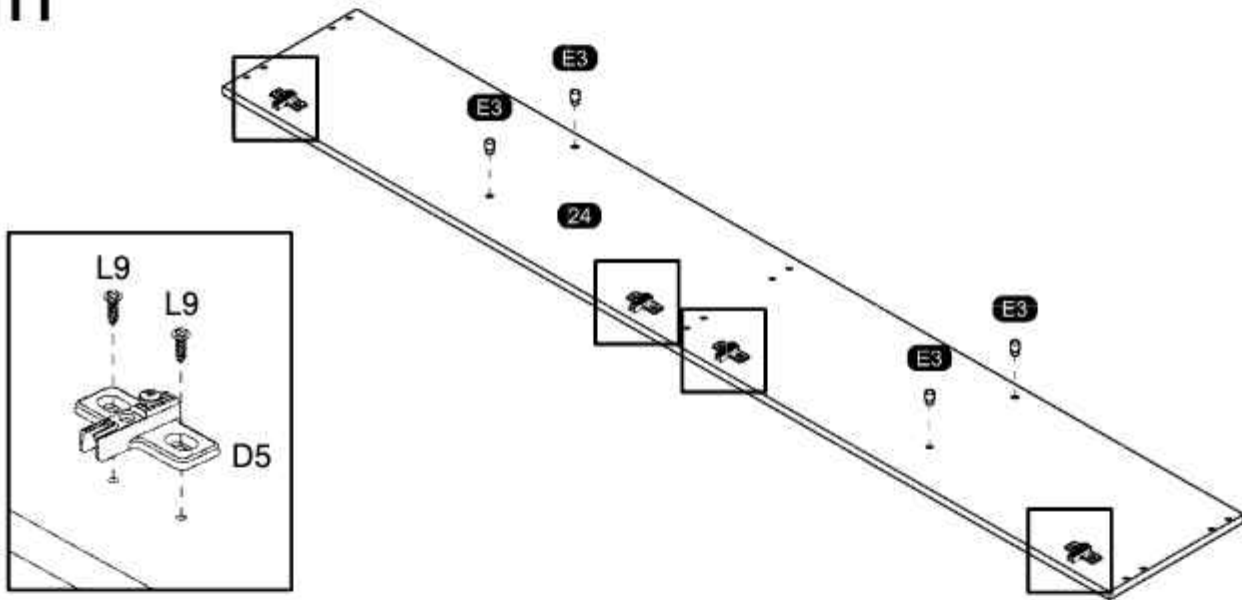

12

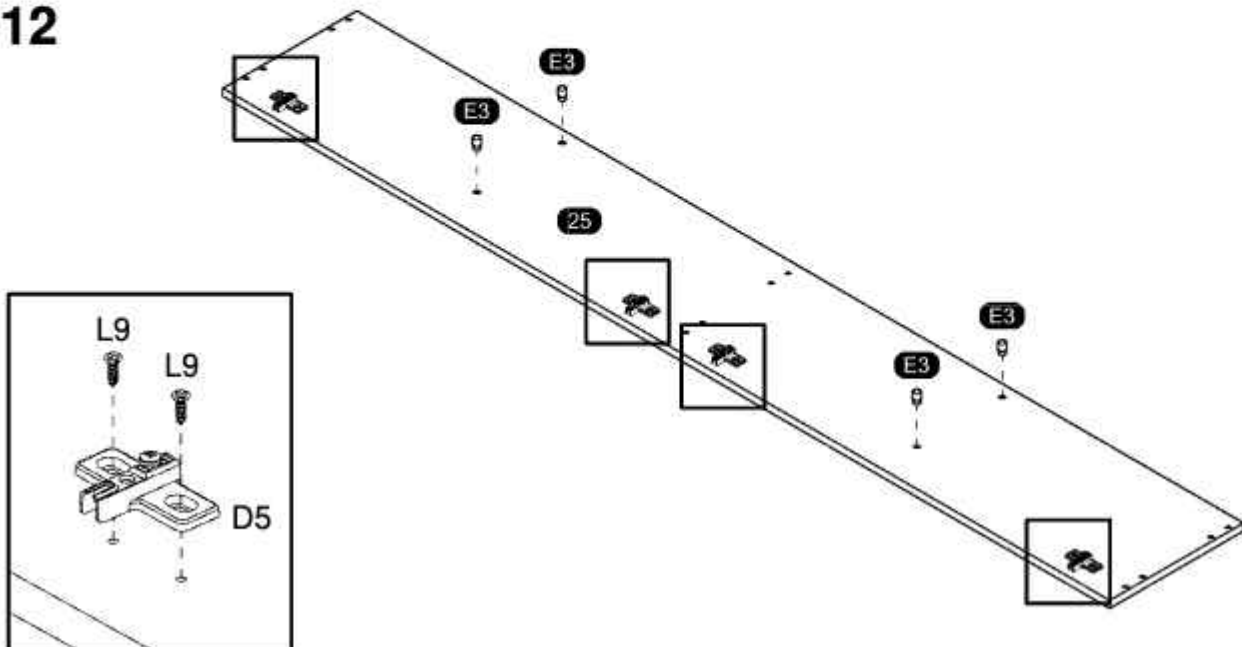

13

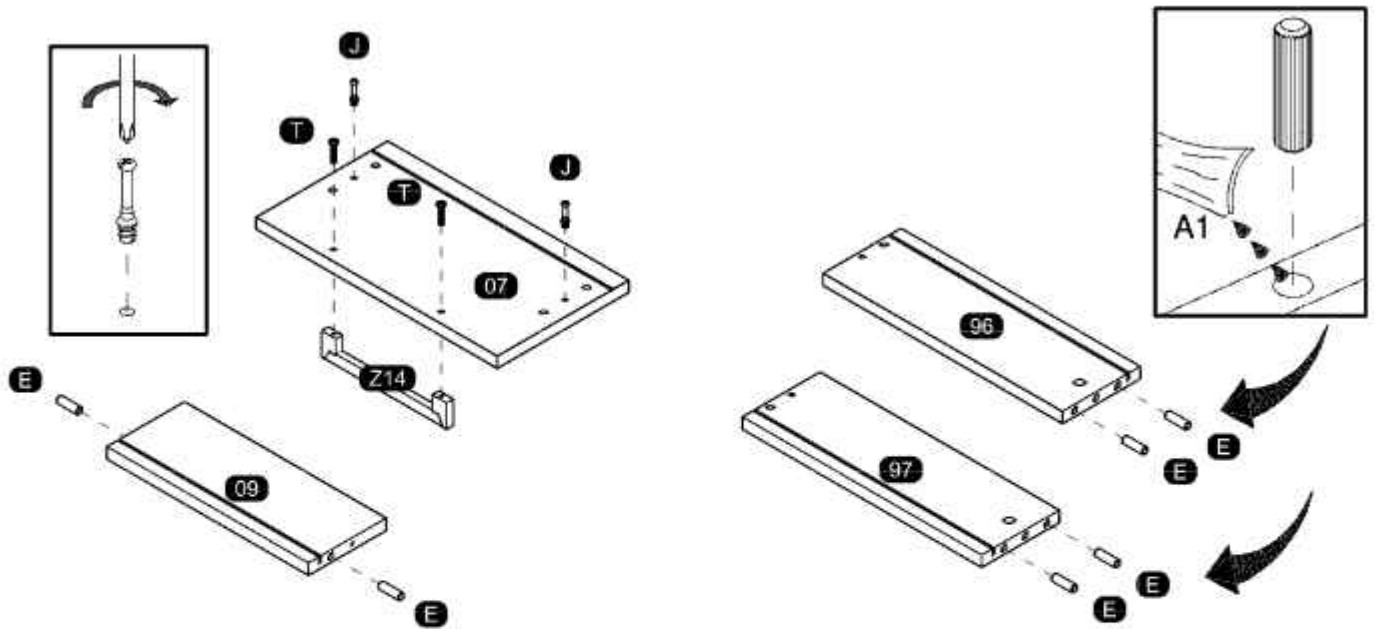

14

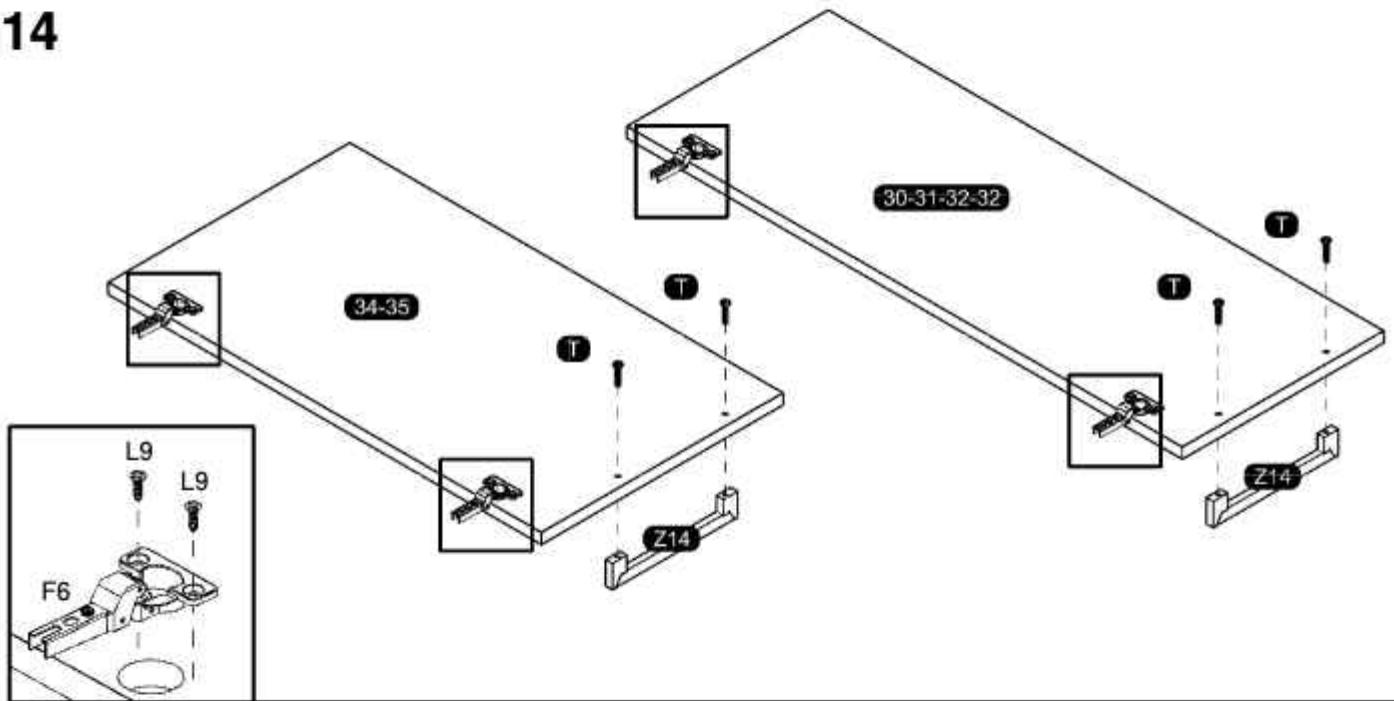

15

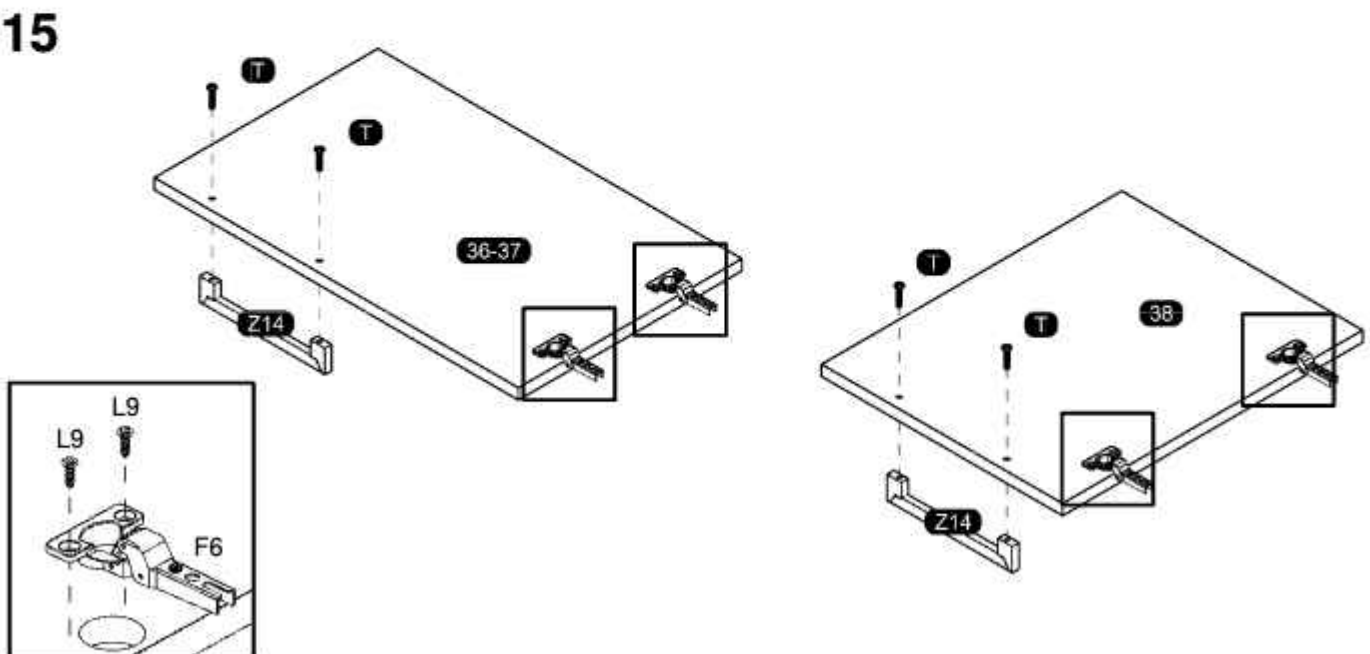

ASSEMBLY
MONTAGEM / ARMADO

16

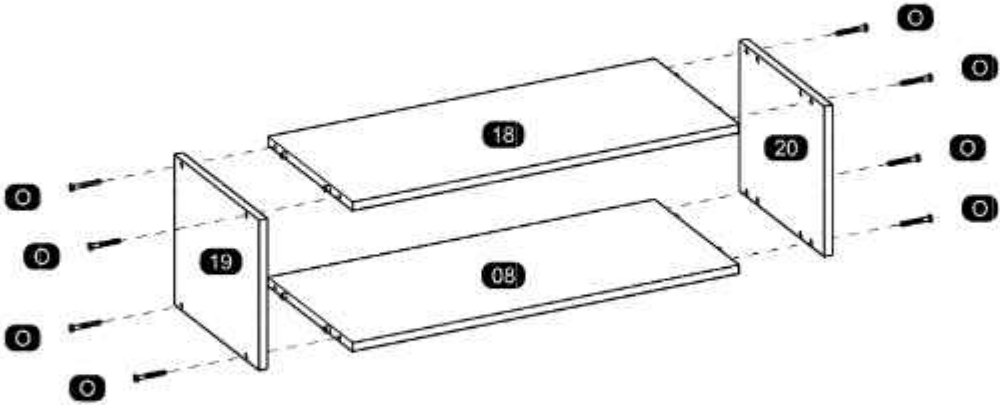

17

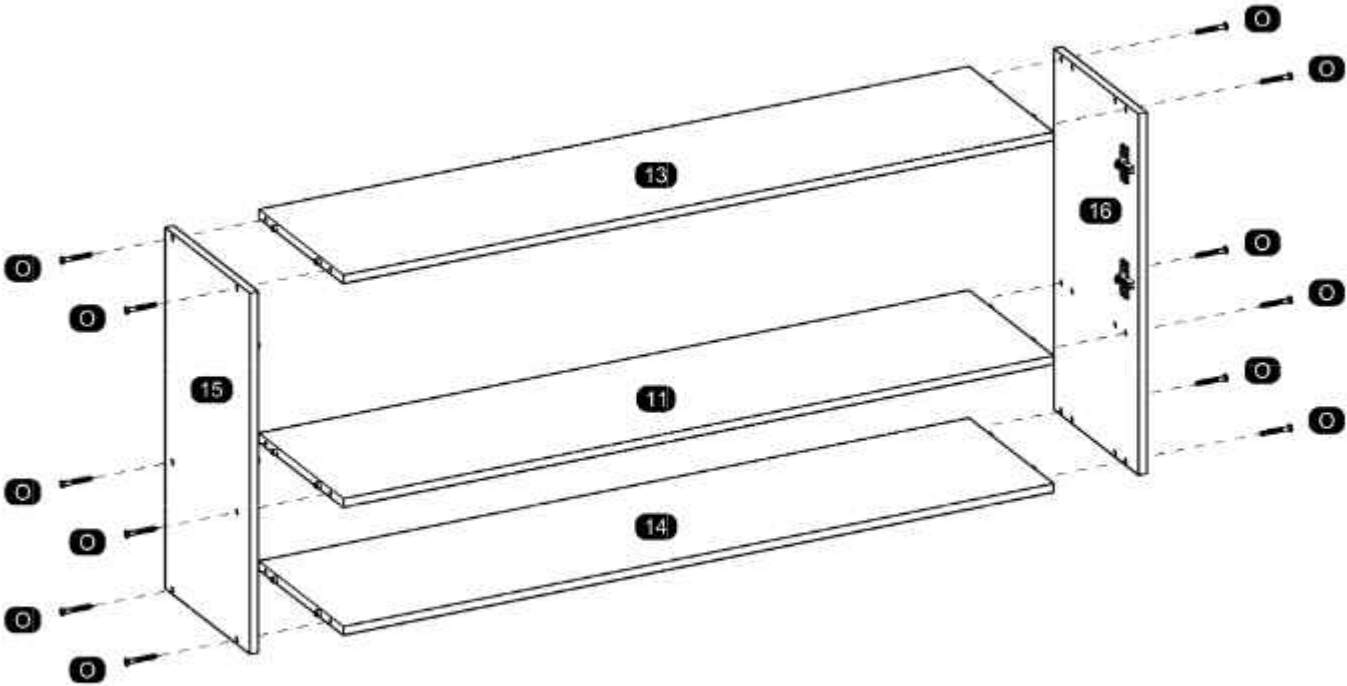

18

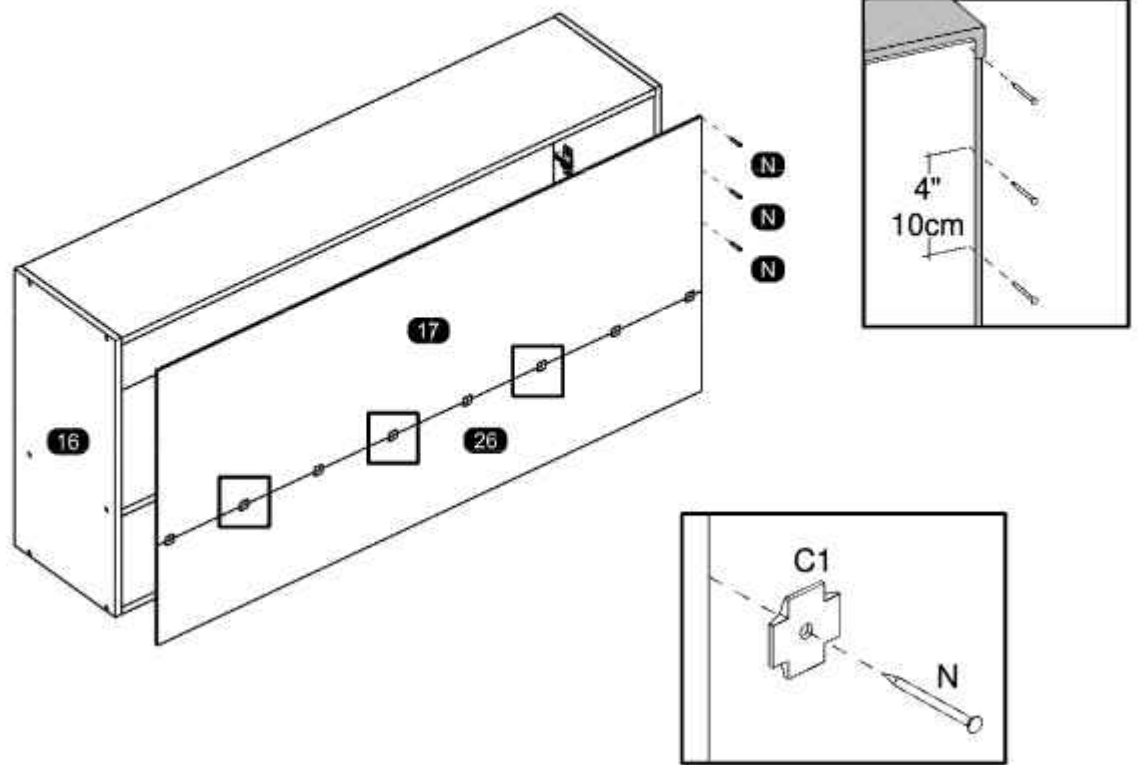

19

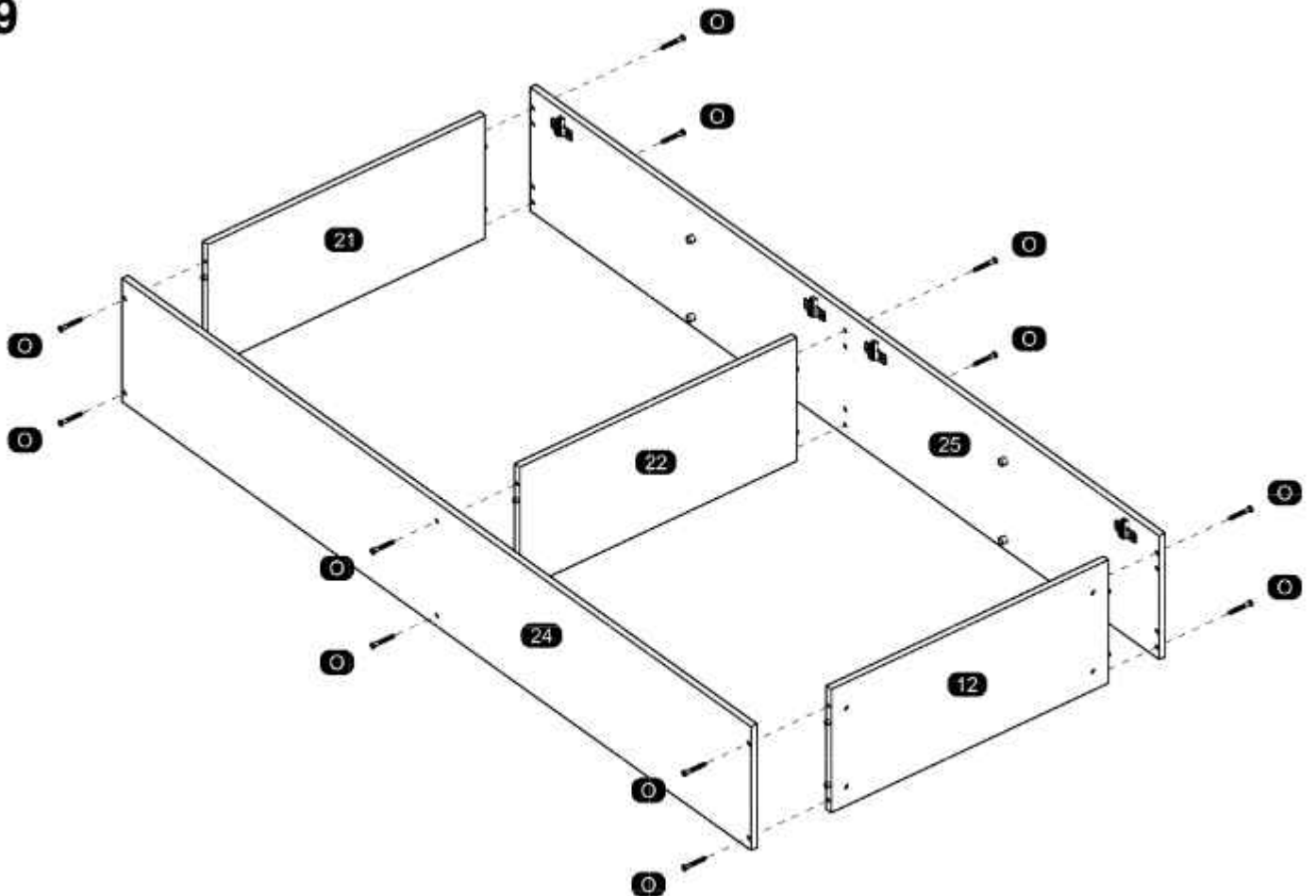

20

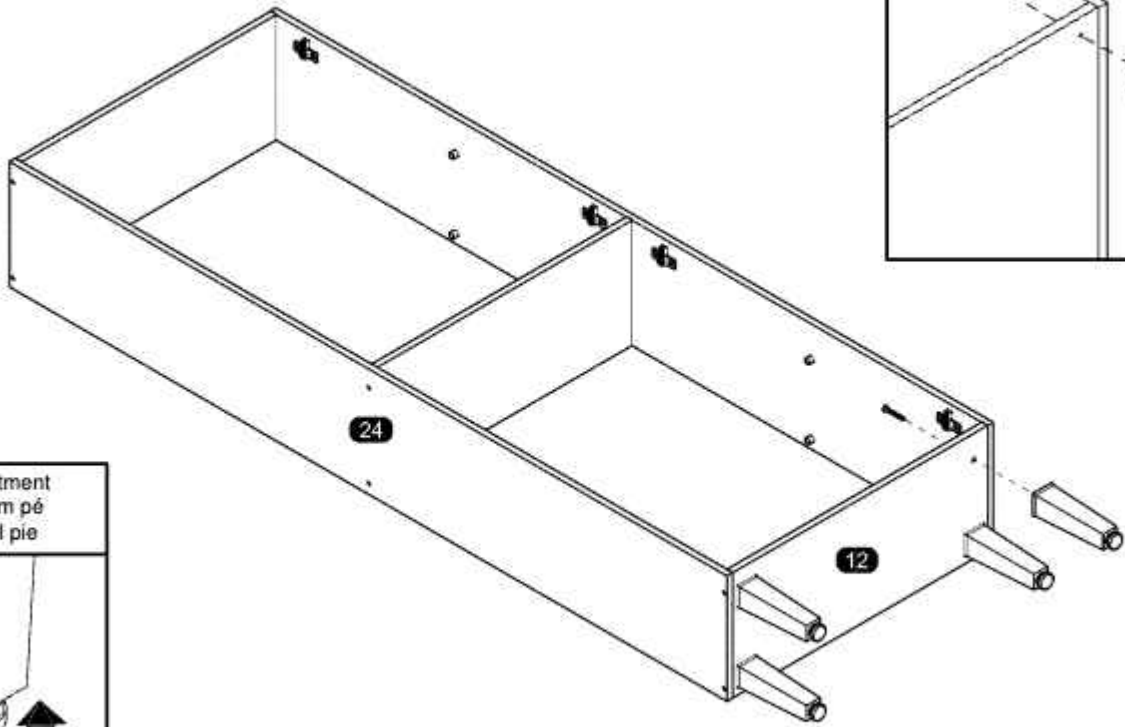

21

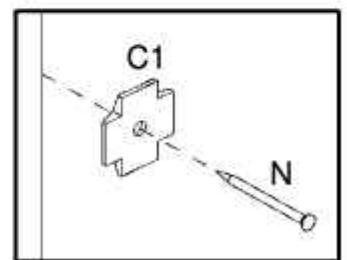
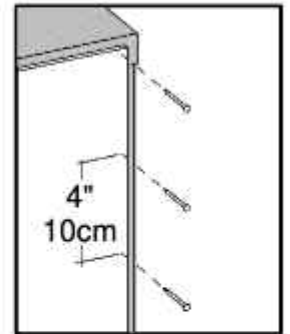
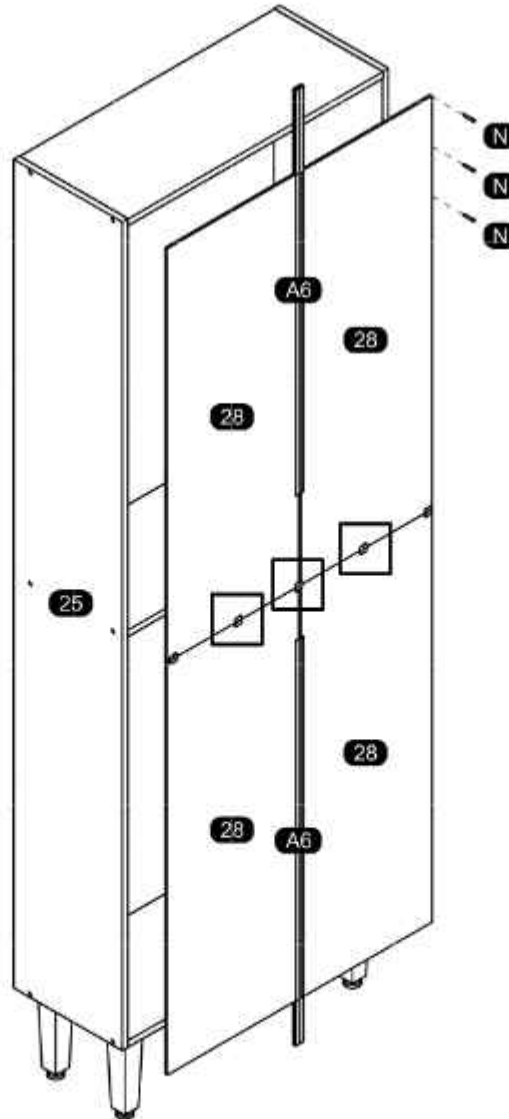

22

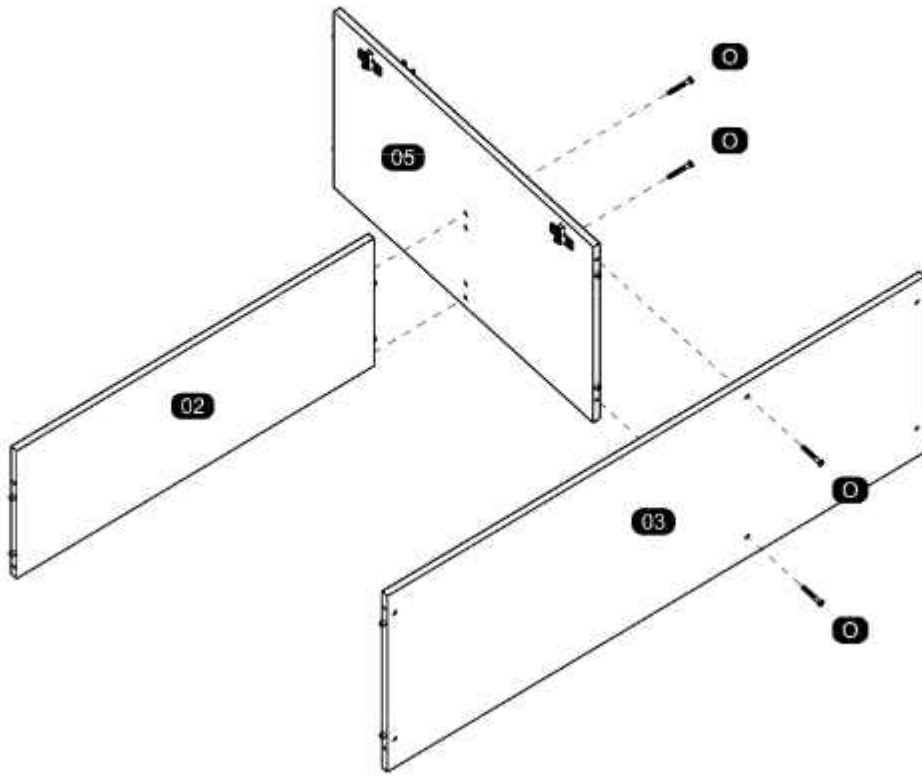

23

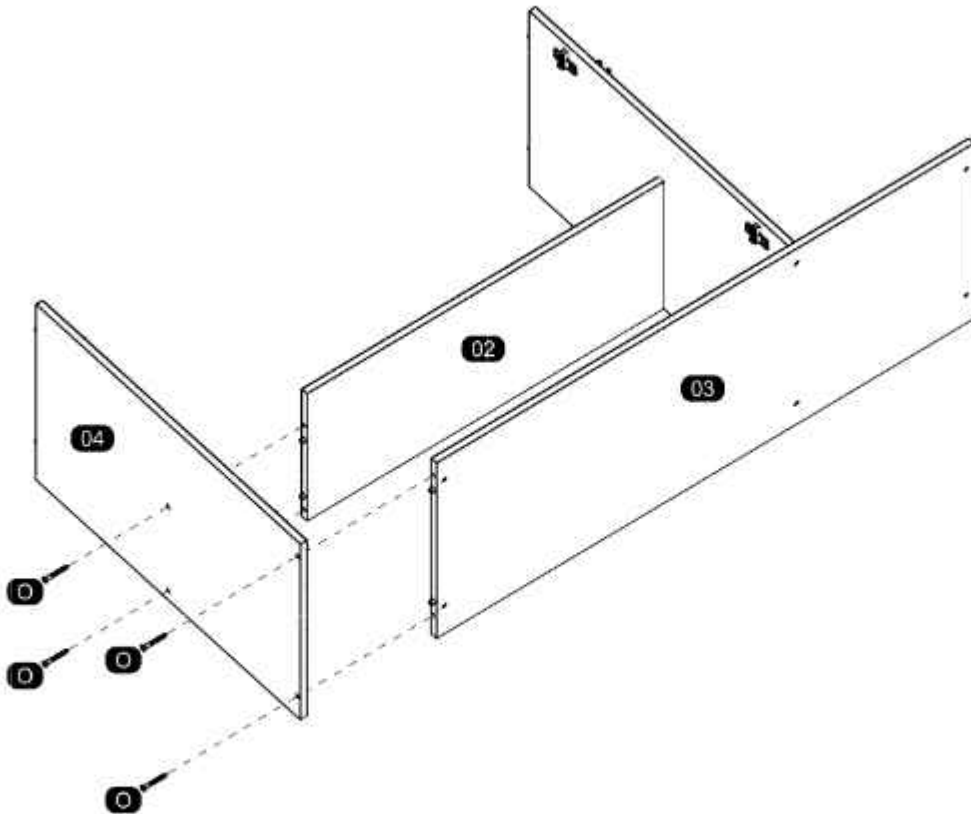

24

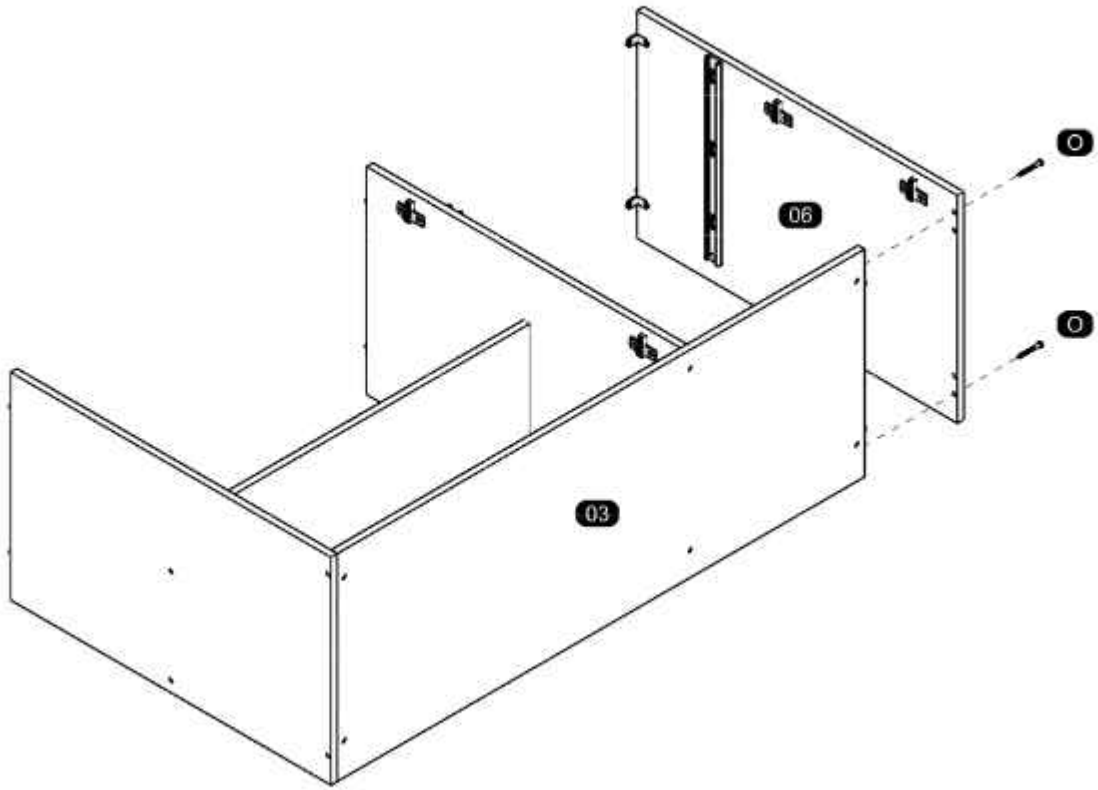

25

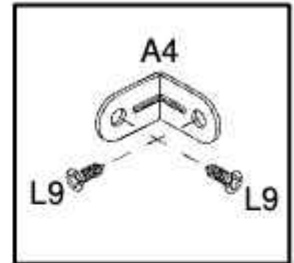
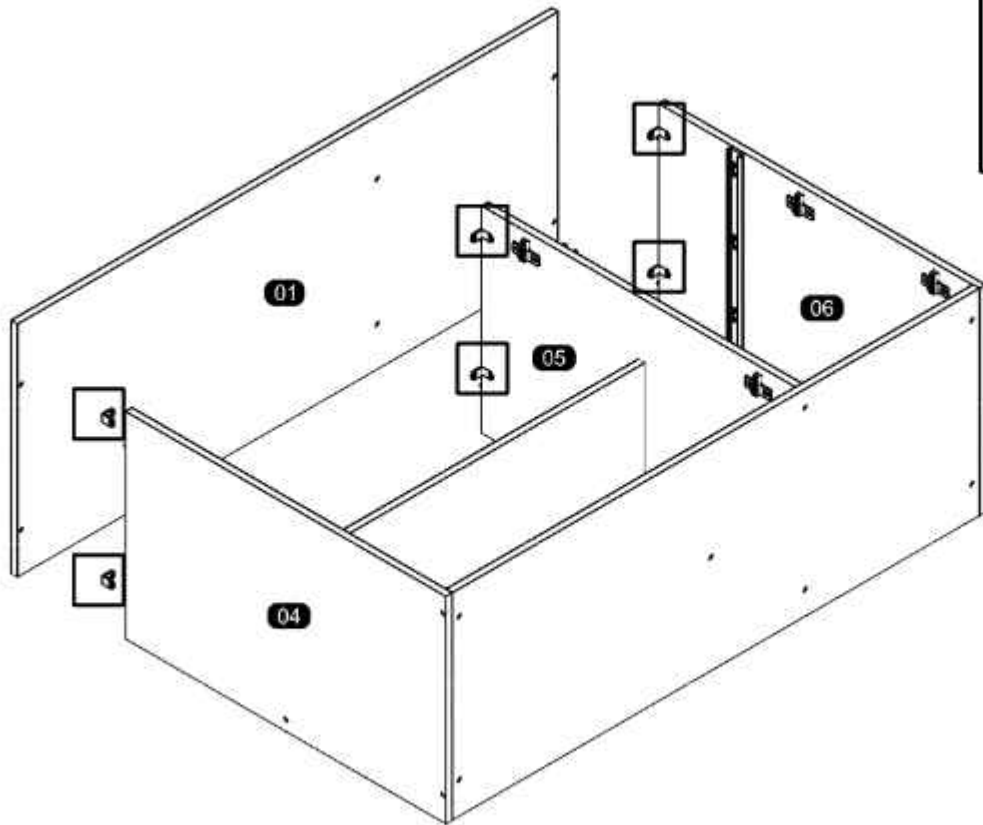

26

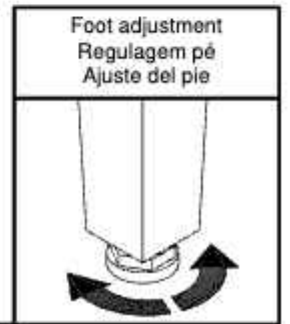
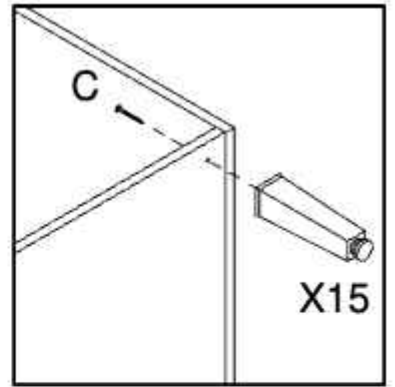
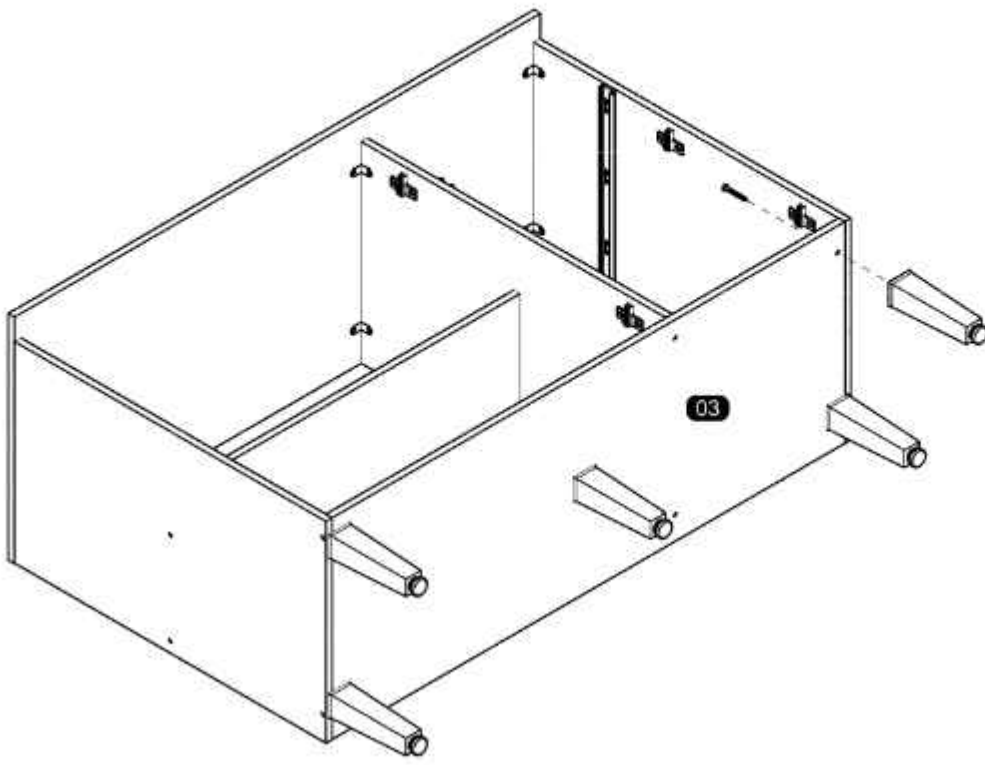

27

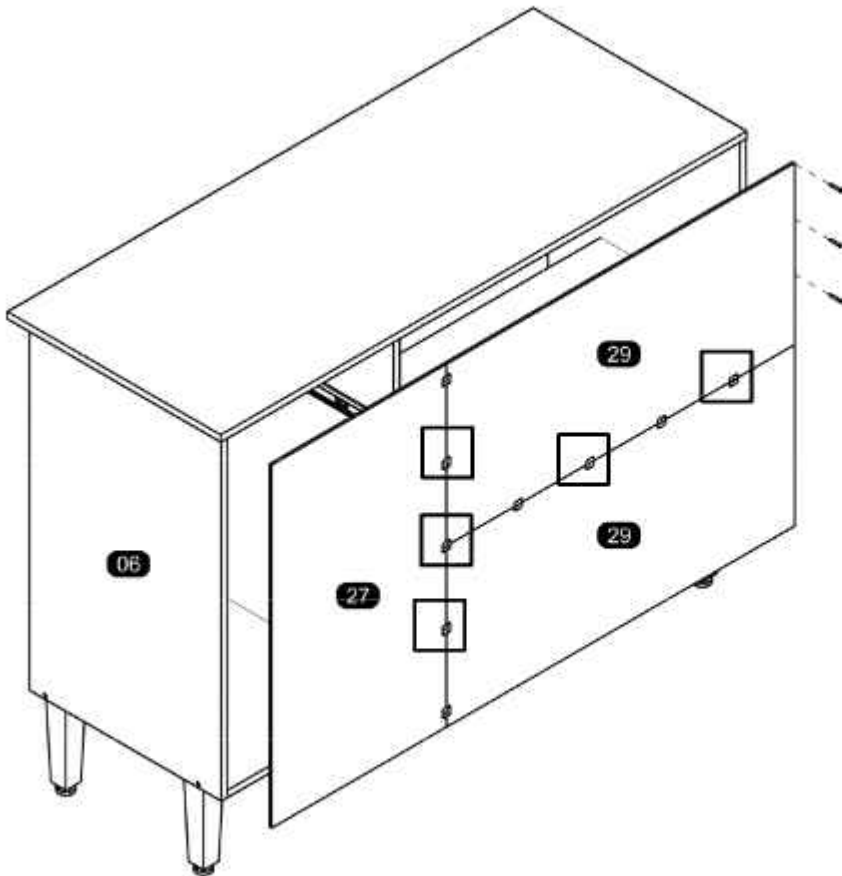

N
N
N

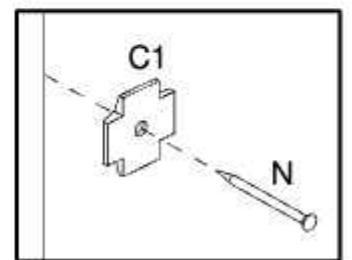
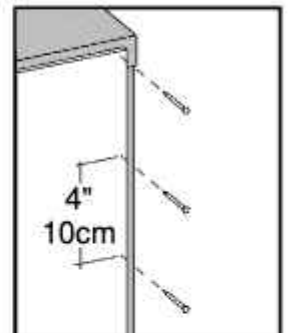

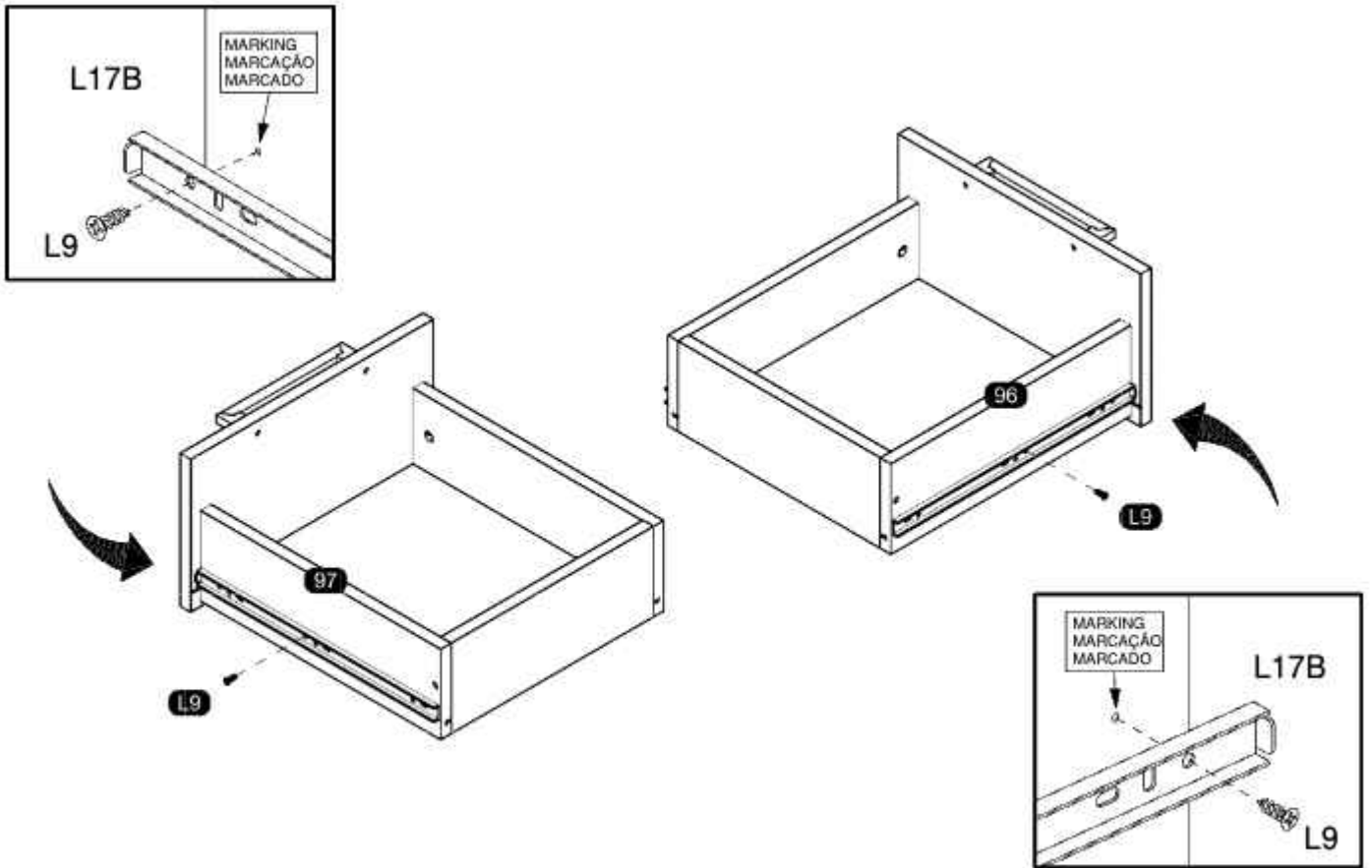
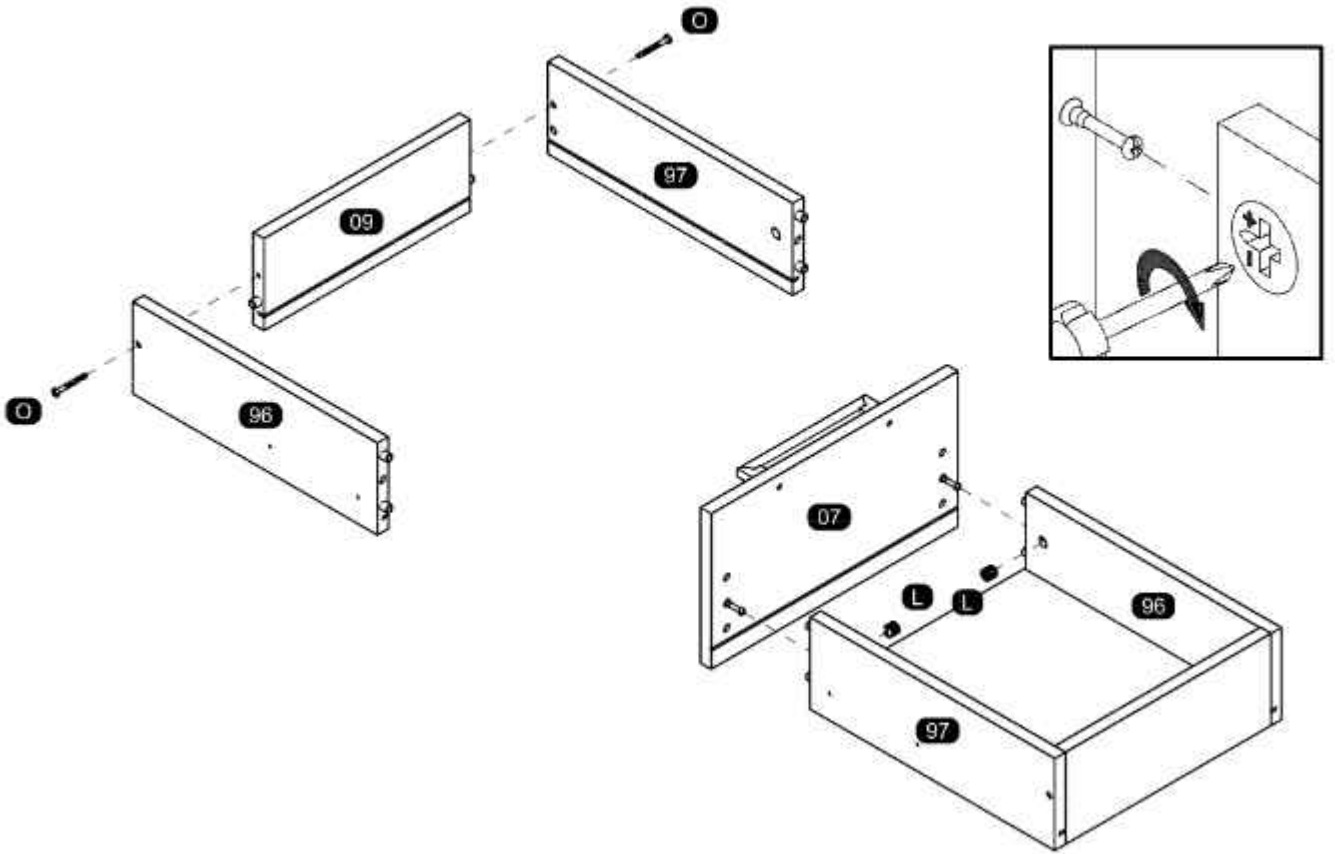

30 (D)

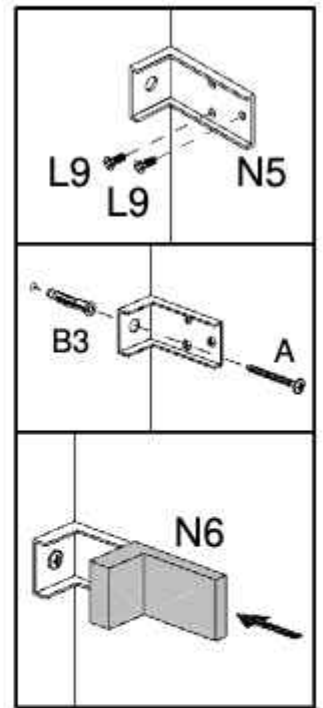
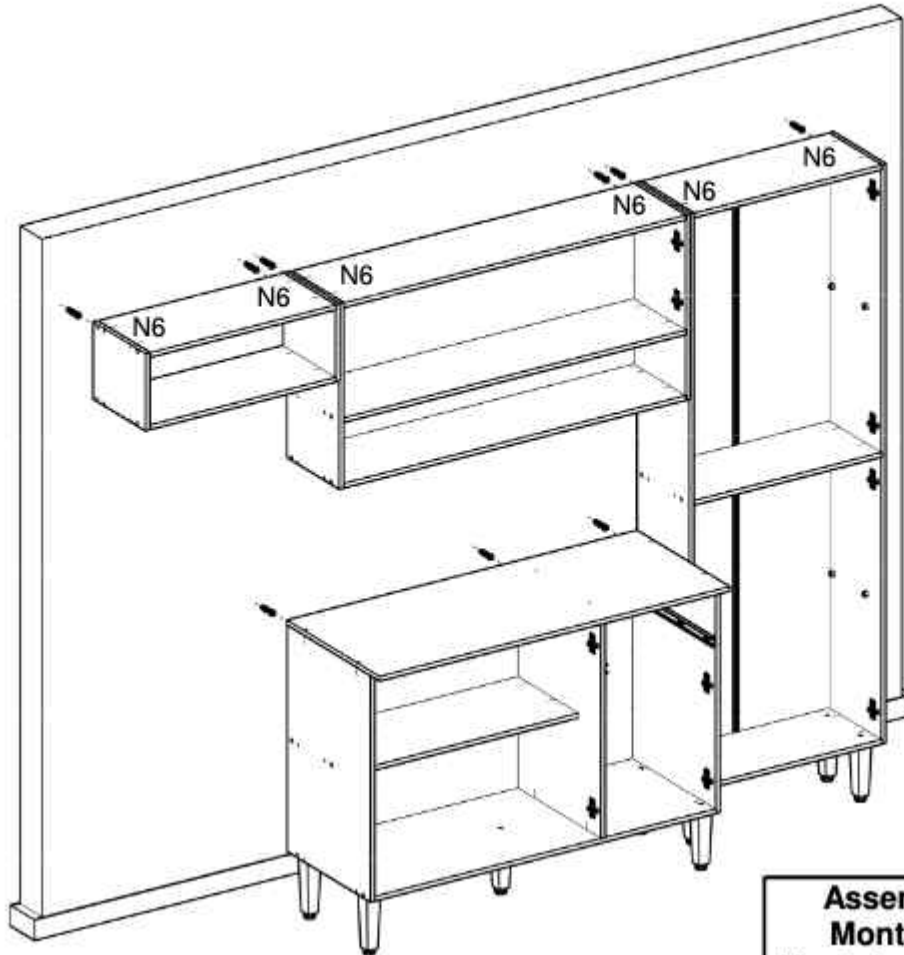

Assembly from THE RIGHT
Montagem para a DIREITA
Montaje para el LADO DERECHO

30 (E)

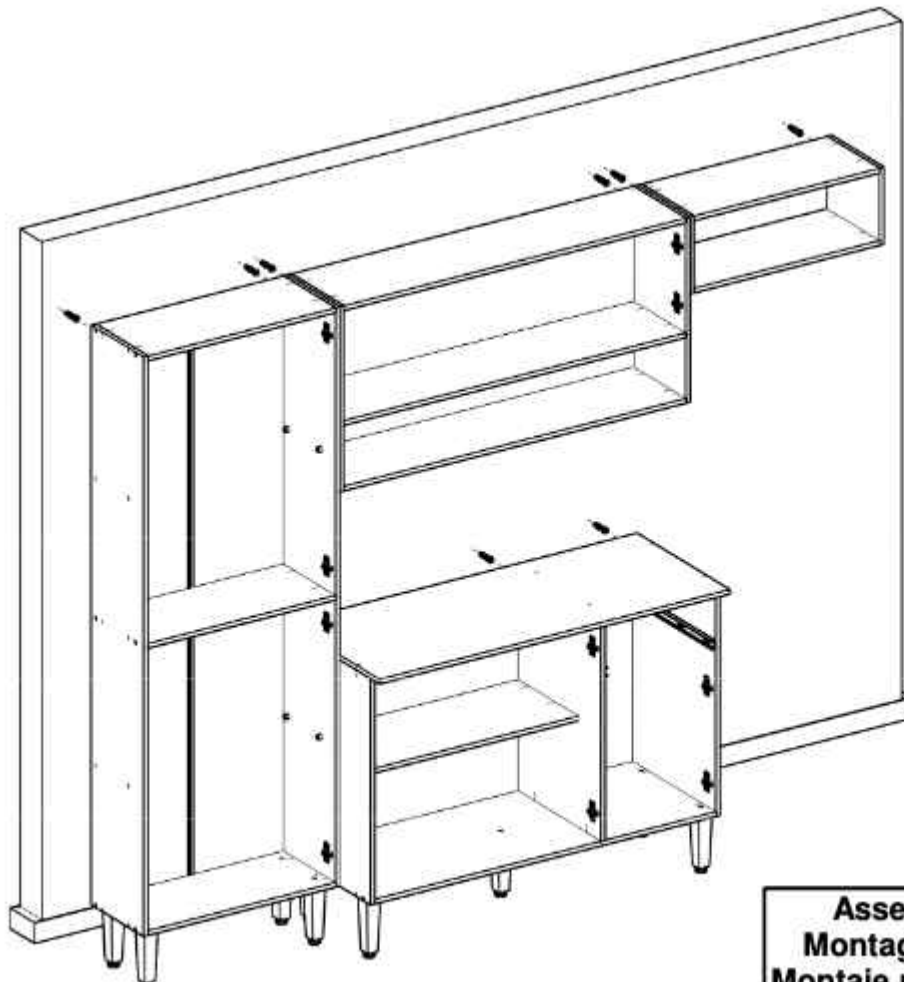

Assembly from THE LEFT
Montagem para a ESQUERDA
Montaje para el LADO IZQUIERDO

31 (D)

At the end of the assembly, insert the screw cover / hole plugs in the apparent holes.
Ao final da montagem, insira a(s) tampa(s) de parafuso / tapa furos nos furos que ficarem aparentes.
Al final del conjunto, coloque la tapa tornillo / tapón plástico en los agujeros que se hagan evidentes.

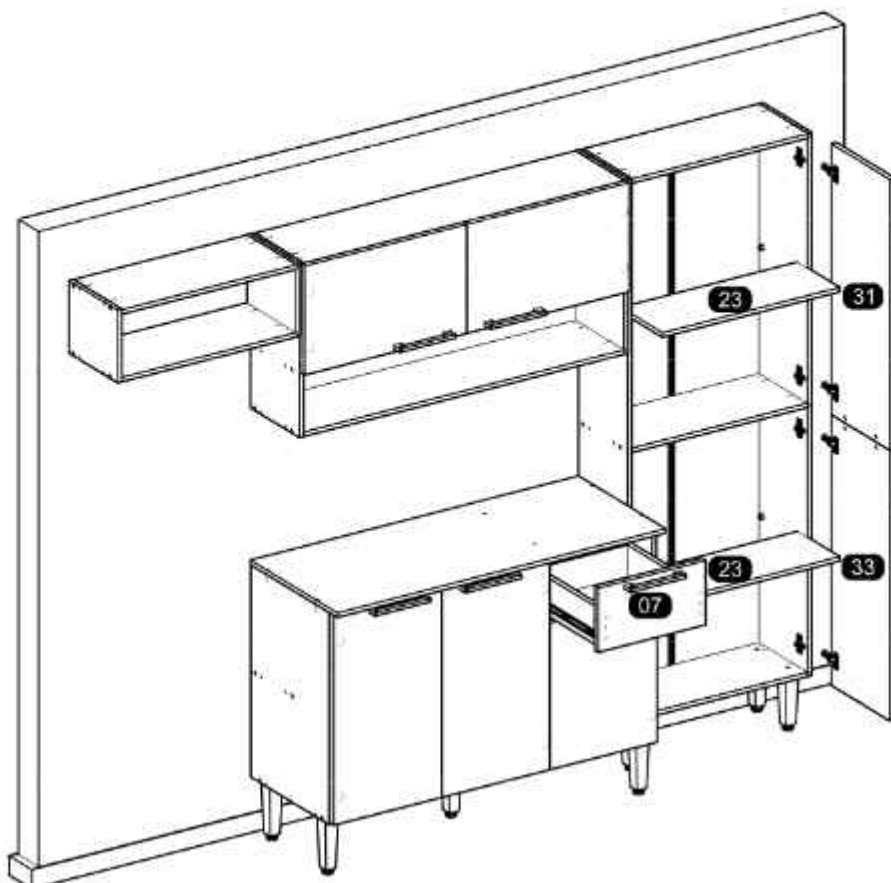
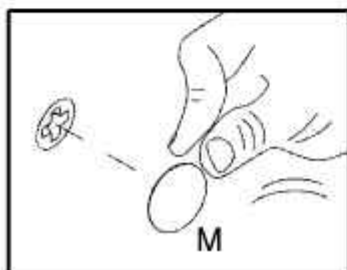
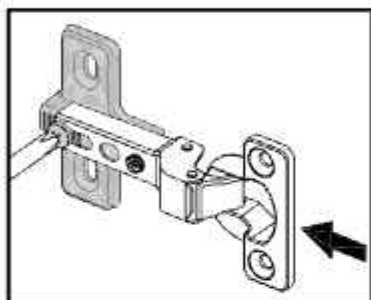

31 (E)

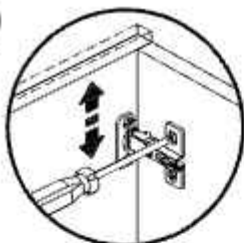

Vertical Adjustment
Regulagem Vertical
Ajuste Vertical

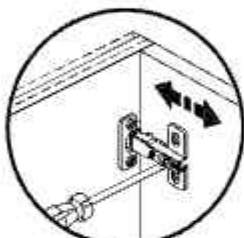

Depth Adjustment
Regulagem Profundidade
Ajuste Profundidad

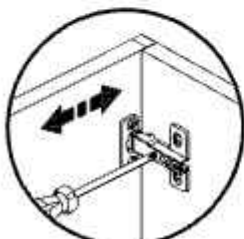

Horizontal Adjustment
Regulagem Horizontal
Ajuste Horizontal

