

196 - GUARDA ROUPA IPÊ

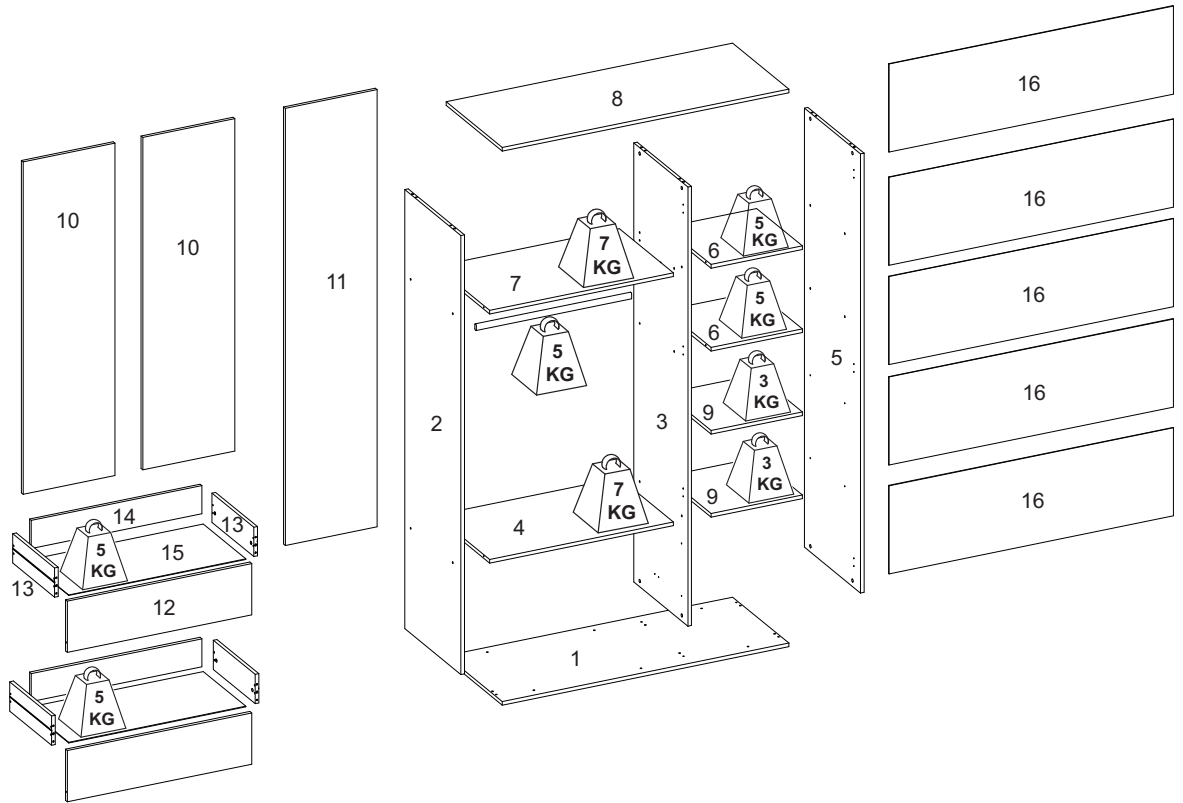

LISTA DE PEÇAS / Pieces List / Lista de Piezas

SEQ.	REF.	DESCRIÇÃO	DESCRIPTION	DESCRIPCIÓN	MAT.PRIMA	COMP.	LARG.	ESP.	QTD.
1	331798	Base	Base	Base	MDF	1198	469	15	1
2	331832	Lateral esquerda	Left side	Lado izquierdo	MDF	1800	467	15	1
3	331800	Divisória	Divider	Divisor	MDF	1800	453	15	1
4	331801	Tampo gaveteiro	Drawer top	Tapa del cajón	MDF	768	452	15	1
5	331802	Lateral direita	Right side	Lado derecho	MDF	1800	467	15	1
6	331803	Prateleira superior	Top shelf	estante superior	MDF	382	382	15	2
7	331804	Base do maleiro	Trunk base	Base del maletero	MDF	768	452	15	1
8	331805	Chapéu	Hat	Sombrero	MDF	1198	469	15	1
9	331806	Prateleira móvel	Mobile shelf	Estante móvil	MDF	382	382	15	2
10	331807	Porta	Door	Puerta	MDF	1359	384	15	2
11	331808	Porta direita	Right door	puerta derecha	MDF	1792	384	15	1
12	331809	Frente de gaveta	Drawer front	Frente del cajón	MDF	771	212	15	2
13	331810	Lateral de gaveta	Drawer side	Lado del cajón	MDF	350	120	15	4
14	331811	Contra fundo	Against background	Contra el fondo	MDF	713	118	15	2
15	331812	Fundo da gaveta	Drawer bottom	Fondo del cajón	HDF	741	355	3	2
16	331813	Fundo	Bottom	Abajo	HDF	1189	361	3	5

INSTRUÇÃO MONTAGEM PRODUTO
 Instructions to Assembly / Instrucciones de montaje

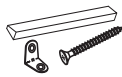

Separe as peças e acessórios de maneira organizada
 Separate parts and accessories in way organized
 Separe las piezas y accesorios de manera organizada

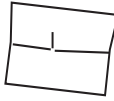

Forrar o chão com o papelão das embalagens.
 Cover the floor with the cardboard
 Cubra el suelo con la embalaje de cartón



É necessário 2 pessoa para montar o produto
 2 people are required to assemble the product
 Se requieren 2 persona para ensamblar el producto

O produto deve ser a montado por um profissional qualificado
 The product must be assembly by a professional
 El producto debe ser ensamblado por un profesional calificado

Ferramentas necessárias
 (não fornecidas)

Not include tools / No herramientas



CUIDADO PARA CONSERVAÇÃO E LIMPEZA DO MÓVEL
 Care to conservation and clean / Cuidados de limpieza

Peso máximo de carga informado refere-se a objetos distribuido de maneira uniforme sobre toda área de contato da peça



The maximum load weight informed refers to objects distributed evenly over the entire contact area of the part
 Conjunto de carga máxima de peso se refiere a objetos distribuidos uniformemente sobre toda el área de contacto de la pieza de trabajo.



Não molhar o móvel e não expor em lugar úmido
 Do not wet the mobile and do not expose in a wet place
 No moje el producto y no exponer en un lugar húmedo



Não expor o móvel próximo de fontes de calor.
 Do not expose the mobile near heat sources
 no exponga cercano de fuentes de calor



Não usar produtos abrasivos.
 Do not use abrasive products.
 No utilice productos abrasivos.



Limpe com flanela limpa e seca.
 Clean with dry cloth
 Limpieza con un paño limpio y seco

LISTA DE ACESSÓRIOS E FERRAGENS / ACCESSORIES AND HARDWARE / ACCESORIOS Y HARDWARE

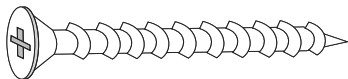

xA- 700137-Parafuso 4,5x45 (16)
 screw / tornillo



B- 701352Parafuso 3,5x30 (18x)
 screw / tornillo



C- 700121-Parafuso 3,5x12 (54x)
 screw / tornillo



D- 700129-Parafuso 4,0x14 (58x)
 screw / tornillo



E- 700130-Parafuso 4,0x16 (08x)
 screw / tornillo



F- 700146-Parafuso minifix (16x)
 Minifix screw /
 Tornillo minifix



G- 700148-Tambor Minifix (16x)
 Minifix Drum /
 Tambor minifix



H- 700542-Cavilha 6x30 (20x)
 peg / cerrojo



I- 700157-Prego (90x)
 nail / clavo



J- 701333-Dobradiça curva
 c/ pistão + calço (03x)
 hinge / bisagra



K- 702941Dobradiça super curva
 c/ pistão + calço (06x)
 hinge / bisagra



L- 700441-Suporte prateleira(08x)
 shelf support/soporte de estantería



M- 702958 - Perfil H (04x)
 Frame / Perfil



N- 702957 - Puxador (05x)
 Handle / Manija



O - 700438 - Suporte cabide (02X)
 hook support / soporte gancho



P - 700113-Corrediça (02x)
 runners / corredera



Q - 702986 - Cabideiro Aluminio (01x)
 Coat Rack / Perchero

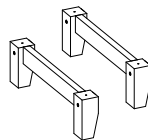

R - 702963 - Pé de madeira chafrado
 kit 2 un com travessa (02)
 Chamfered wooden foot kit 2 units with platter
 Pie de madera biselado kit 2 unidades con plato

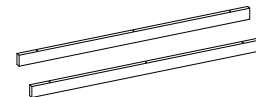

S - 702965 - Travessa de madeira (02X)
 Wooden platter / plato de madera



T - 702962 - Pé de madeira reto (01X)
 Straight wooden foot /
 Pie de madera recto

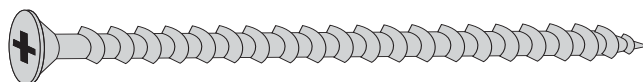

U- 702966 - Parafuso 4,5x85 (04x)
 screw / tornillo

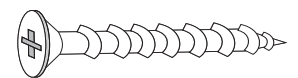

V- 700136-Parafuso 4,5x35 (09x)
 screw / tornillo



W- 700419-Tapa furo (28x)
 cover / tapa



Y- 700516- Cola(01X)
 Glue / Goma



Z - 700433-Suporte angular (4x)
 Angled support / Soporte en ángulo

01° PASSO - Fixar os acessórios nas peças 2,3 e 5

01° STEP - Fix accessory to parts 2,3 and 5

01° PASO - Fijar el accesorio las partes 2,3 y 5

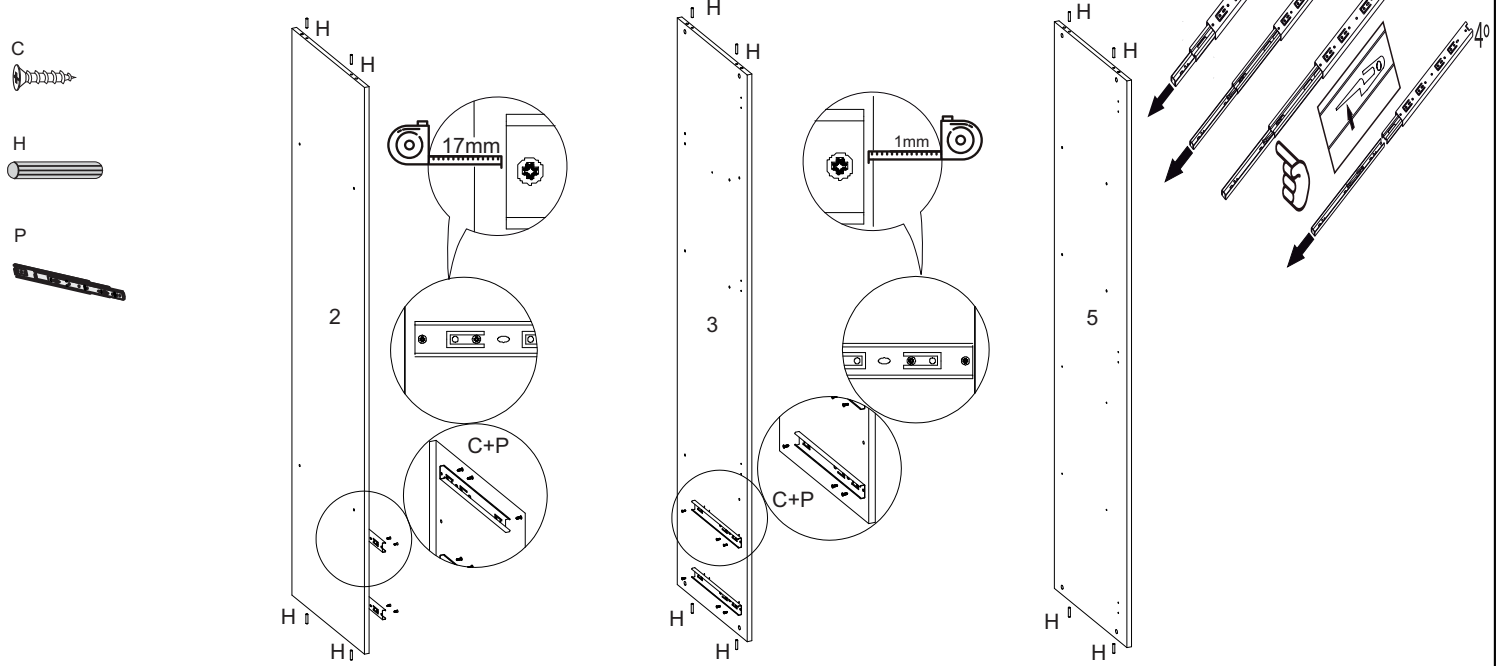

02° PASSO - Fixar os acessórios (R+S) com o acessório (U)

02° STEP - Fix the accessories (R+S) with the accessory (U)

02° PASO - Fije los accesorios (R+S) con el accesorio (U)

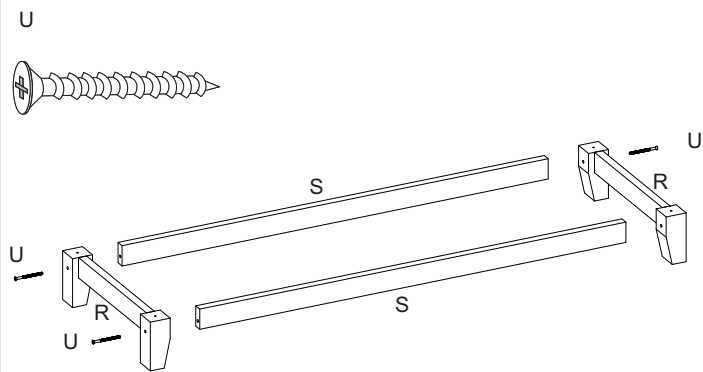

03° PASSO - Fixar peça 1 no kit pé

03° STEP - Fix part 1 to the foot kit

03° PASO - Fijar la parte 1 al kit de pies

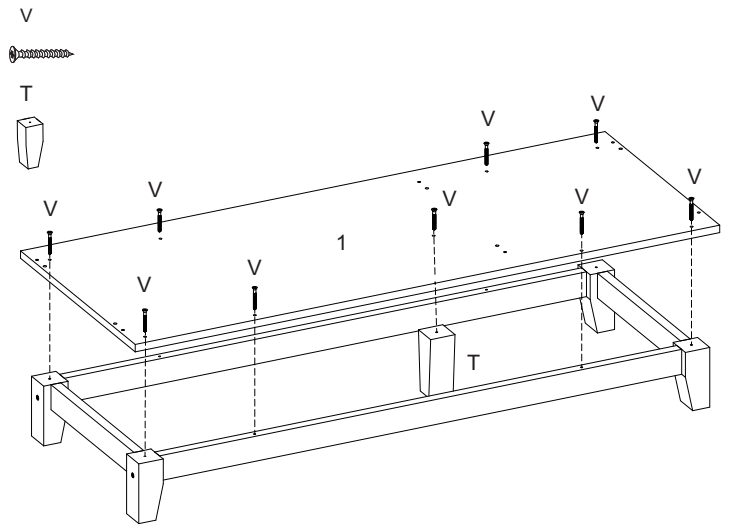

04° PASSO - Fixar acessório (F) na peça 1

04° STEP - Fix accessory (F) to part 1

04° PASO - Fijar el accesorio (F) a la parte 1

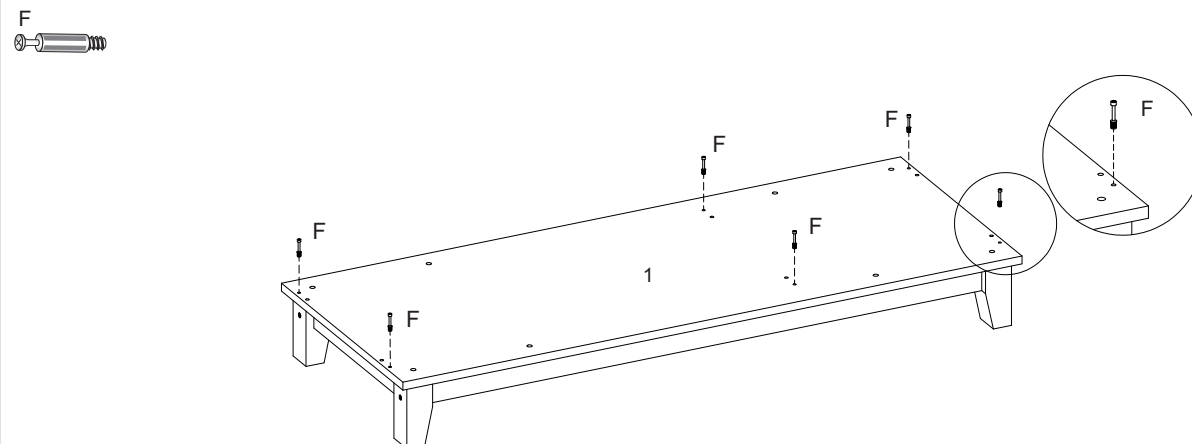

05° PASSO - Fixar peças 2 e 3 na peça 1

05° STEP - Fix parts 2 and 3 to part 1

05° PASO - Fijar las piezas 2 y 3 a las pieza 1

G

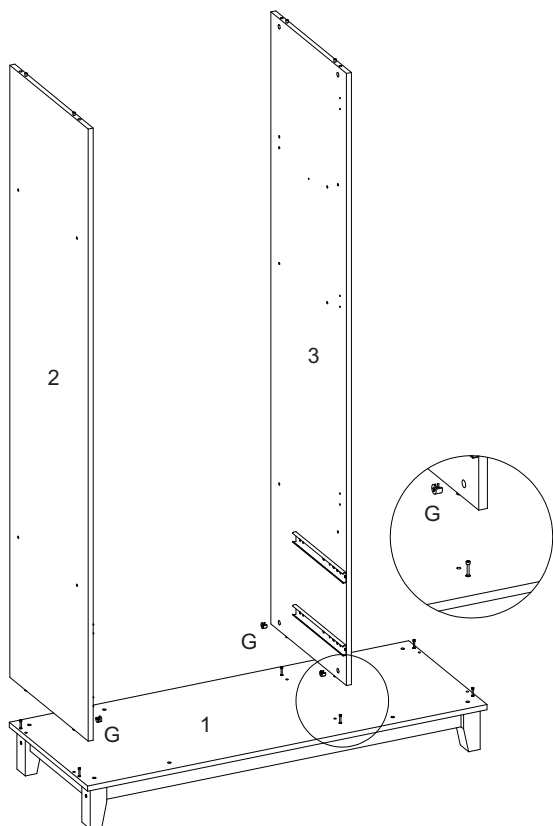

06° PASSO - Fixar peça 4 e 7 nas peças 2 e 3

06° STEP - Fix parts 4 and 7 to parts 2 and 3

06° PASO - Fijar las piezas 4 y 7 a las piezas 2 y 3.

A

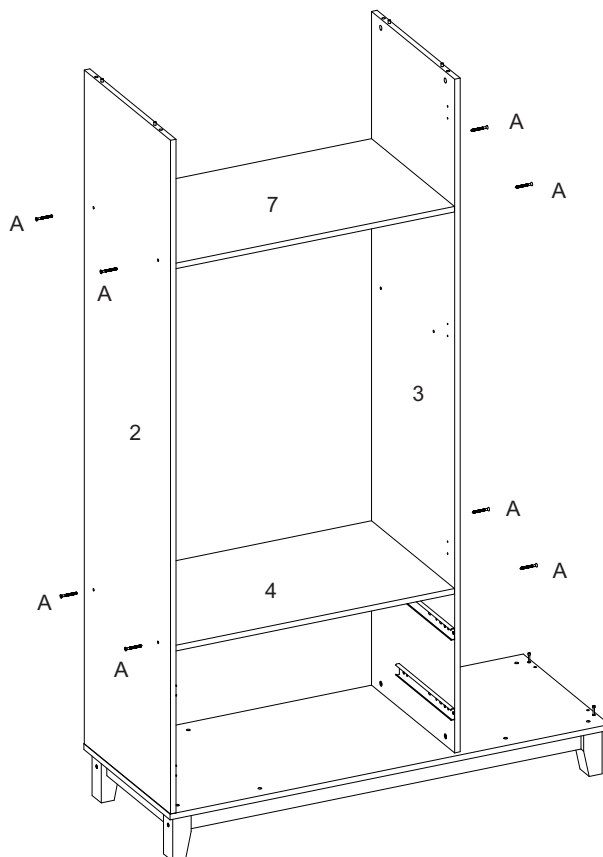

07° PASSO - Fixar peça 5 na peça 1

07° STEP - Fix parts 5 to part 1

07° PASO - Fijar las pieza 5 a la pieza 1.

G

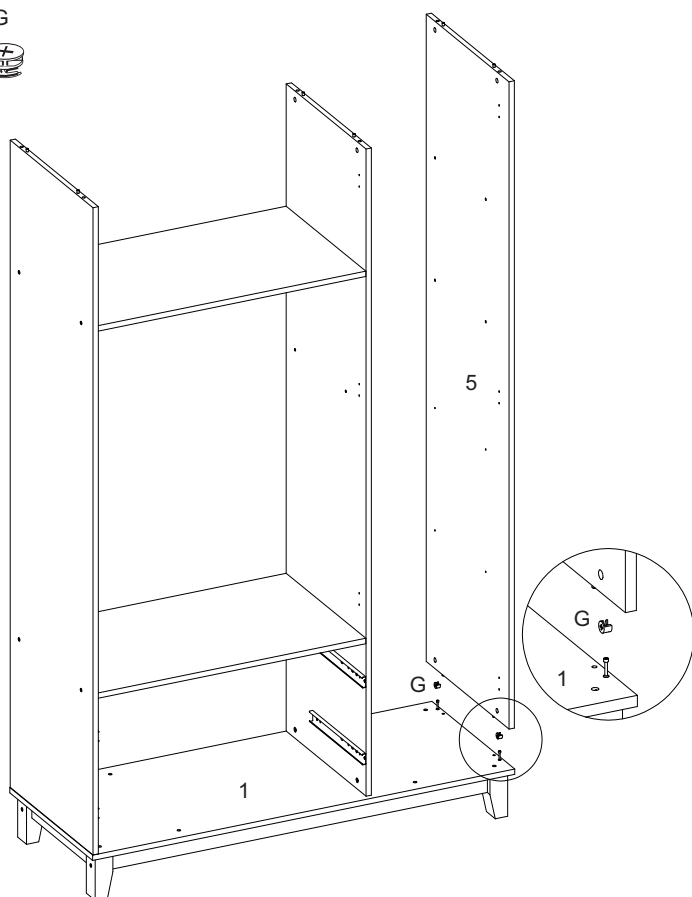

08° PASSO - Fixar peça 6 nas peças 3 e 5

08° STEP - Fix part 6 to parts 3 and 5

08° PASO - Fijar las pieza 6 a la piezas 3 y 5 .

A

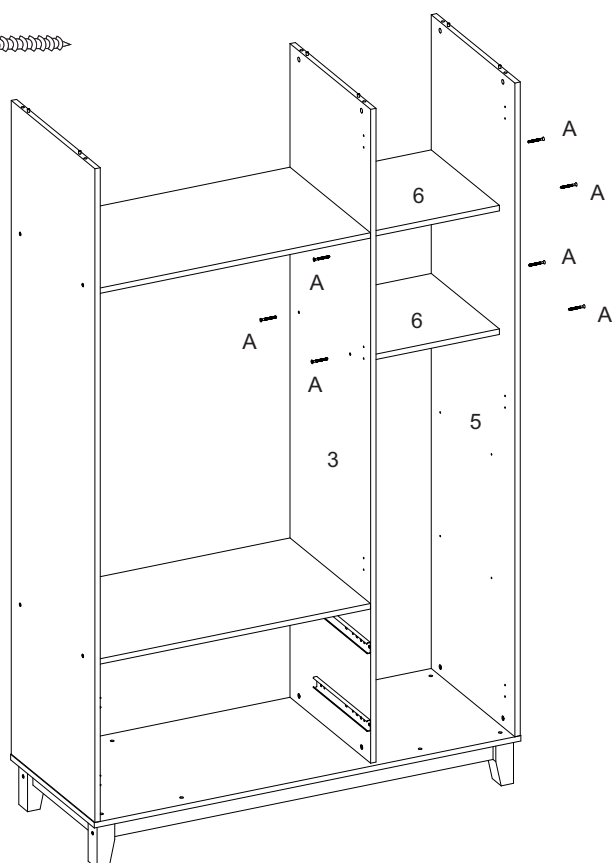
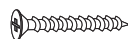

09º PASSO - Fixar peça 8 nas partes 2,3 e 5

09º STEP - Fix part 8 to parts 2,3 and 5

09º PASO - Fijar la parte 8 a las partes 2,3 y 5.

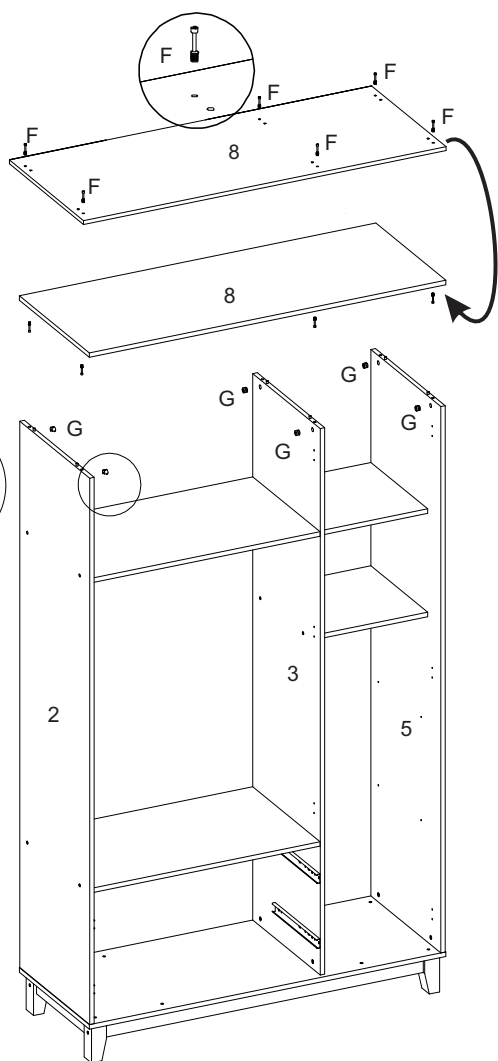

10º PASSO - Fixar peças 16 na parte de trás do produto

10º STEP - Fix parts 16 to the back of the product

11º PASO - Fijar las piezas 16 en la parte posterior del producto.

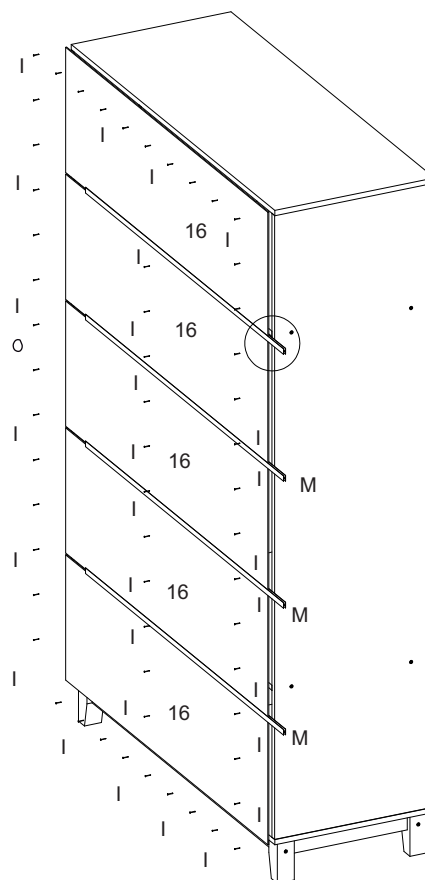

11º PASSO - Encaixar as peças 9 nas peças 3 e 5

11º STEP - Fit parts 9 into parts 3 and 5

11º PASO - Encaja las piezas 9 en las piezas 3 y 5.

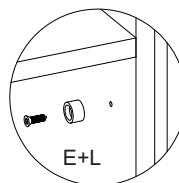
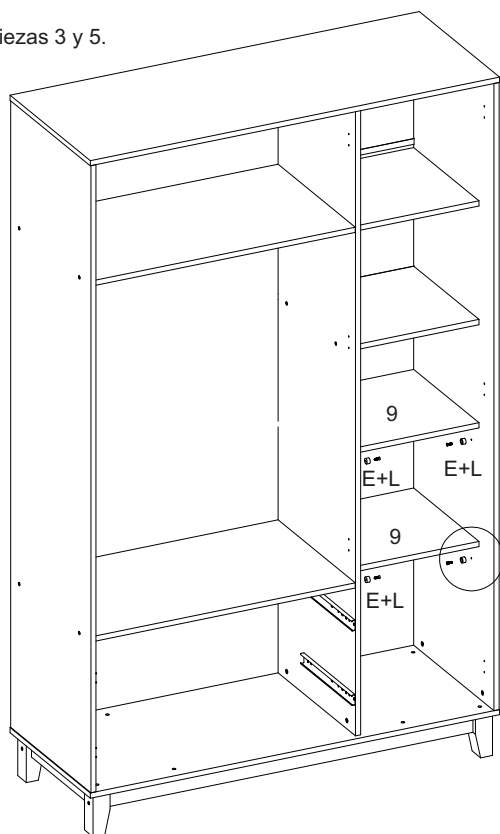

12º PASSO - Fixar acessórios (D+K) na peças 10 e 11

12º STEP - Fix accessories (D+K) to parts 10 and 11

12º PASO - Fijar los accesorios (D+K) a las piezas 10 y 11

D



K



J



Utilizar acessório J em uma das peça 10

Use accessory J in one of the parts 10

Utilice el accesorio J en una de las piezas 10

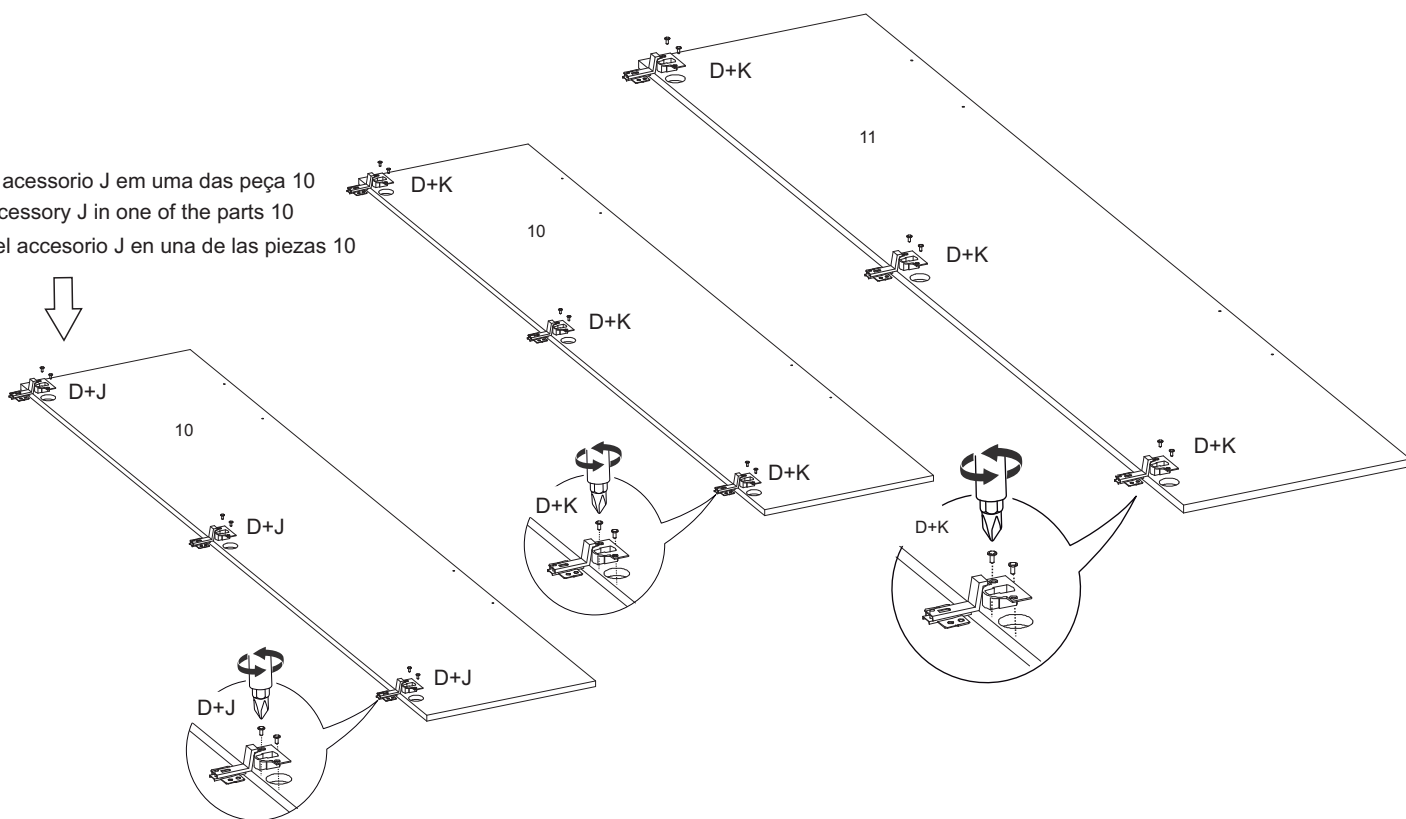

13º PASSO - Fixar peças 10 e 11 nas peças 2,3 e 5

13º STEP - Fix parts 10 and 11 to parts 2,3 and 5

13º PASO - Fijar la partes 10 y 11 a las parts 2,3 y 5.

D

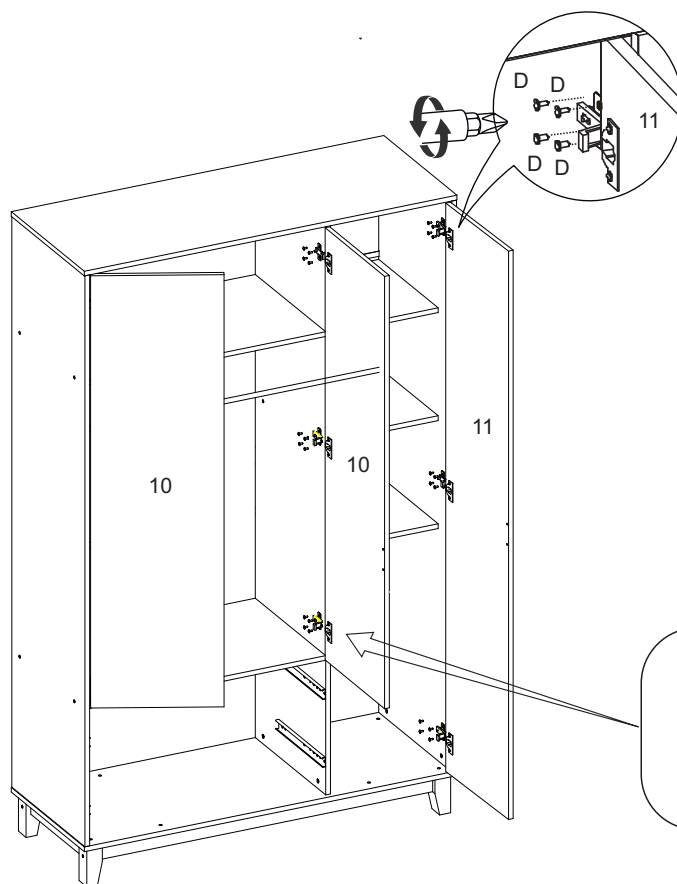

Porta com o acessório J
Port with accessory J
Puerto con accesorio J

14° PASSO - Fixar s acessórios B+N nas peças 10 e 11

14° STEP - Fix accessories B+N to parts 10 and 11

14° PASO - Fijar los accesorios B+N a las piezas 10 y 11.

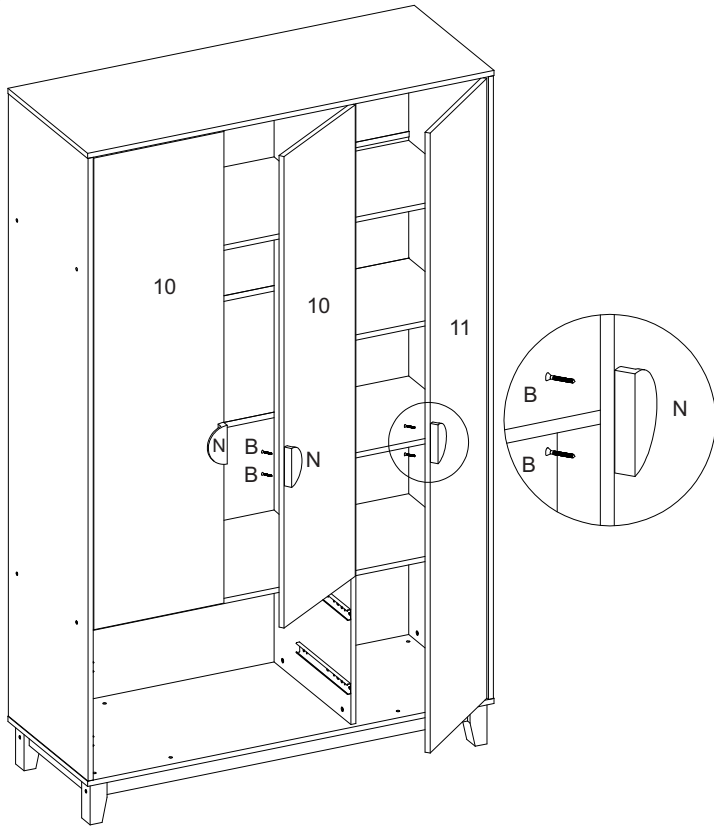

15° PASSO - Fixar peças 13 nas peças 12 e 14

15° STEP - Fix parts 13 to parts 12 and 14

15° PASO - Fijar las piezas 12 a las piezas 13 y 14.

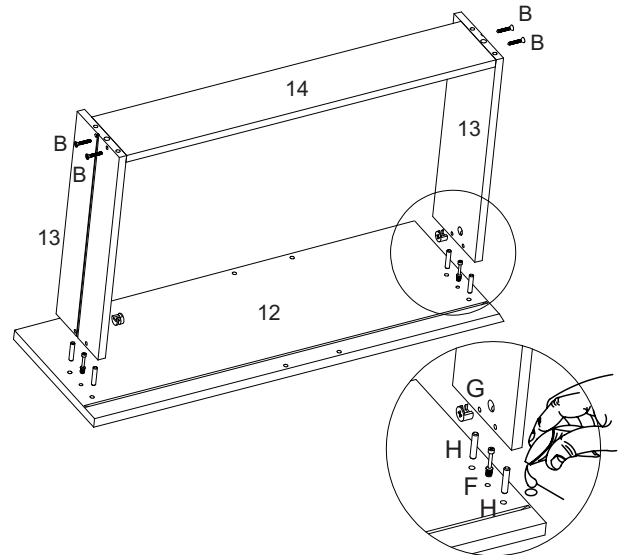
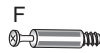

16° PASSO - Fixar peças 15 nas peças 13 e 14, fixar os acessório Z na peça 12

16° STEP - Attach pieces 15 to pieces 13 and 14, attach accessories Z to piece 12

16° PASO - Fije las piezas 15 a las piezas 13 y 14, fije los accesorios Z a la pieza 12

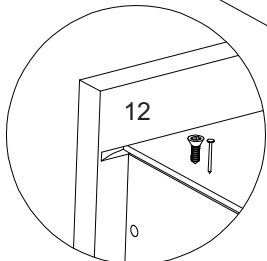
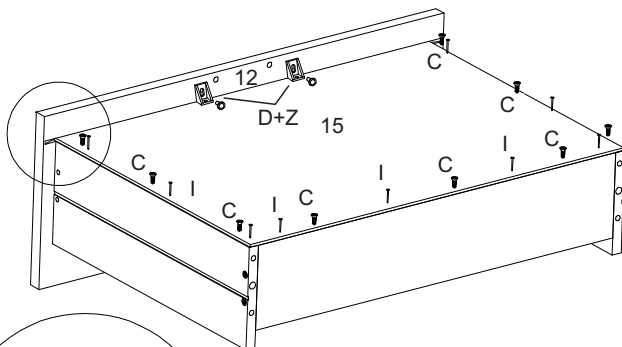
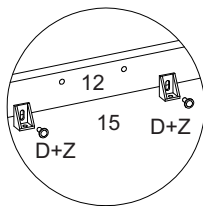

17° PASSO - Fixar acessórios C+P na peça 13

17° STEP - Fix accessorie C+P to parts 13

17° PASO - Fijar los accesorio C+P a las piezas 13

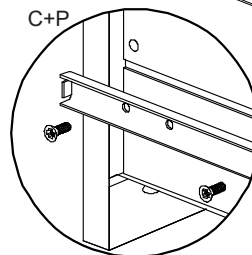
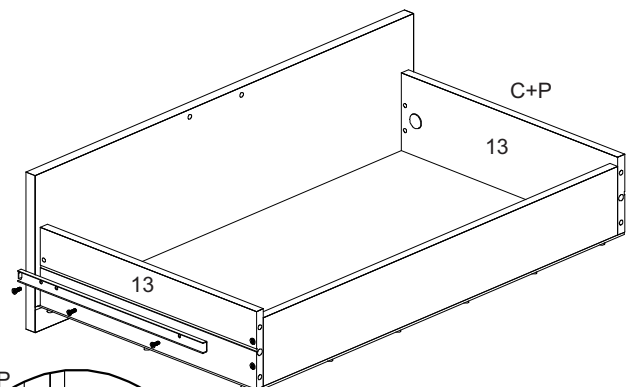

18° PASSO - Encaixar as gavetas.Fixar acessórios B+N na peças 12

18° STEP - Fit the drawers. Fix B+N accessories to parts 12

18° PASO - Colocar los cajones .Fijar los accesorios B+N a las piezas 12

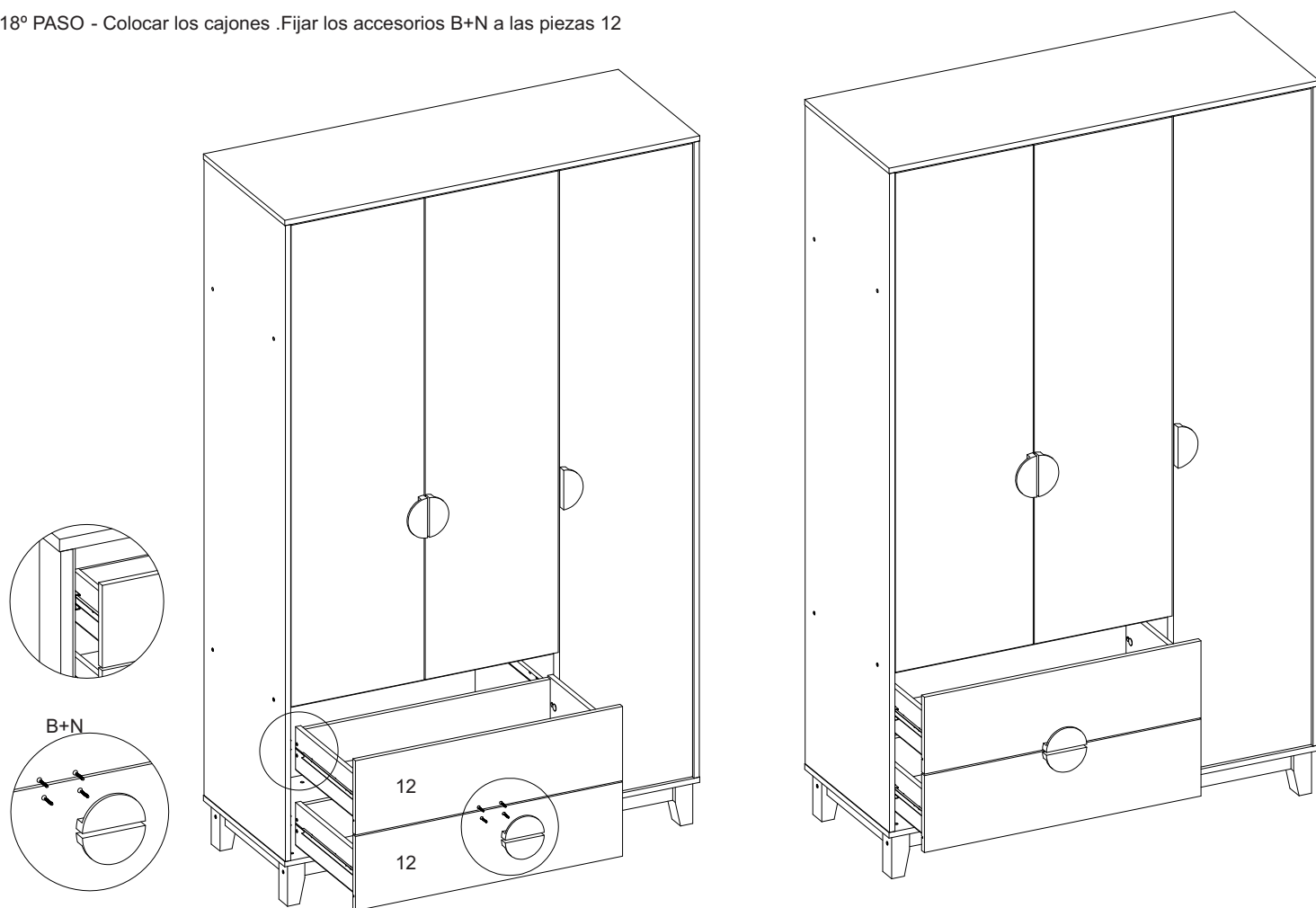

Aspecto final do produto

Final product aspect

Aspecto final del producto

