

Passo 4:

Fixe as Longarinas N° 05 com Pregos 12 x 12 'C'.
Fixe a Etiqueta Móveis Estrela 'G' na parte superior direita da Peseira N° 03.

Step 4:

Fix the pieces No. 05 with 'C'.
Fix 'G' on the right top of the piece No. 03.

Paso 4:

Fije el No. 05 piezas por 'C'.
Fijar 'G' en la parte superior derecha de la pieza No. 03.

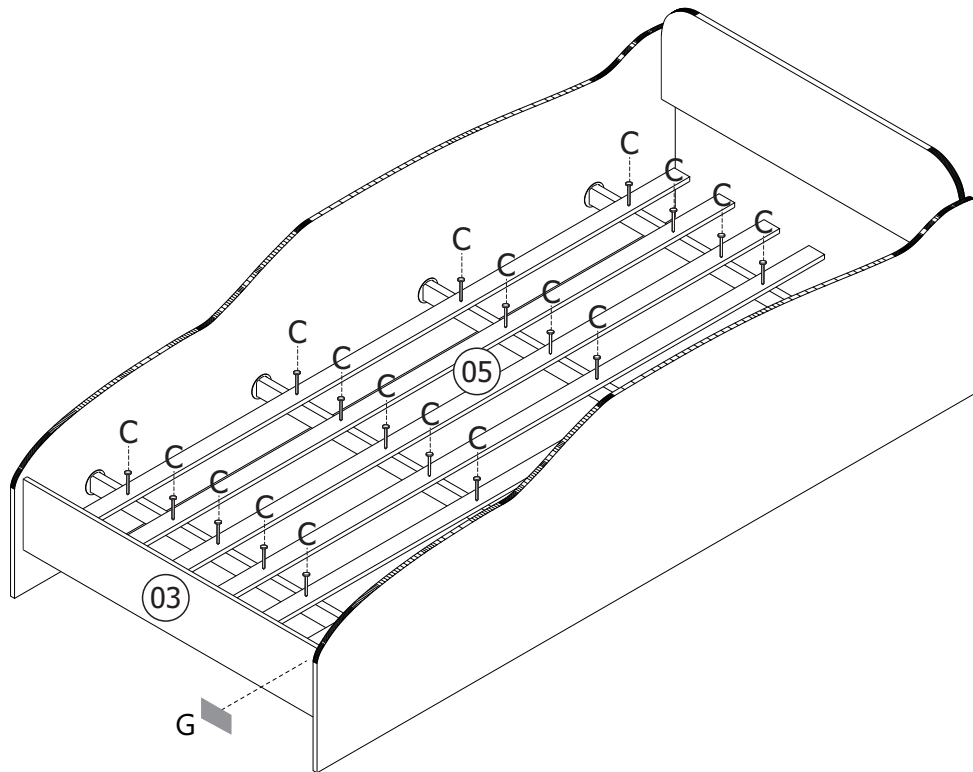
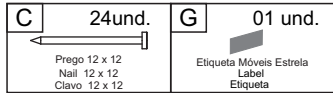

M.E. GONÇALVES
INDÚSTRIA DE MÓVEIS LTDA.
Avenida Maracanã, 4244 - Parque Industrial
Arapongas - PR - Brasil
Fone: + 55 (43) 3274-8800
www.moveisestrela.com.br

MANUAL DE INSTRUÇÕES

MANUAL DE INSTRUCCIONES

INSTRUCTION MANUAL

CERTIFICADO

90

dias

GARANTIA

CAMA EVOLUTION CAR - 9A / Cama ULTRASONIC CAR - 9A
EVOLUTION CAR BED - 9A / ULTRASONIC CAR BED - 9A
CAMA EVOLUTION CAR - 9A / Cama ULTRASONIC CAR - 9A

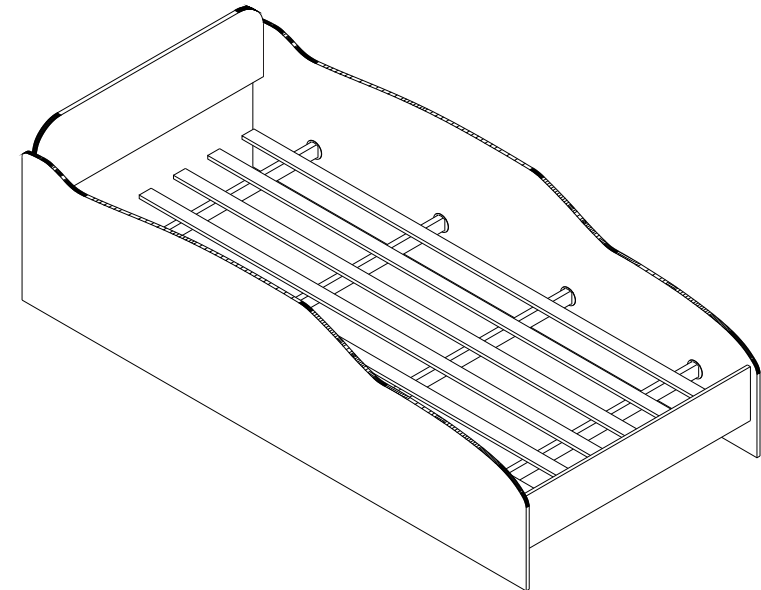

SUA CASA, SEU ESTILO

"Imagens meramente ilustrativas, sujeitas a alterações sem aviso prévio"

"Image merely illustrative, subject to change without prior notice"

"Imágenes ilustrativas, pueden ser cambiadas sin aviso previo"



1 Adulto
1 Adult
1 Adulto

Pessoas Necessárias para montagem

Necessary people for assembly

Gente necesaria para la asamblea

Ferramentas Necessárias (Não Incluídas)

Tools needed (not included)

Herramientas necesarias (no incluido)



Martelo
hammer
martillo



Parafusadeira
Screwdriver
destornillador



Chave Fenda
Slot Key
Clave de runura



Chave Phillips
Phillips Key
Clave Phillips

INFORMAÇÕES SOBRE SEGURANÇA

1. Esta embalagem contém peças pequenas, mantenha afastada de crianças até que o produto esteja montado.
2. As instruções são genéricas, as figuras podem variar.
3. Leia atentamente todas as instruções antes de iniciar a montagem.
4. Separe e guarde a etiqueta de identificação.
5. Confira se os volumes e quantidades de peças descritos no manual estão corretos.
6. Identifique as peças e separe os acessórios.
7. A montagem do produto deverá ser feita em uma superfície limpa e plana. Aconselhamos utilizar a própria embalagem para forrar o chão a fim de não danificar o produto.
8. Reservar área livre para montagem do produto.
9. Evitar batidas e o contato com objetos cortantes.
10. Não expor o móvel a calor excessivo (luz solar direta), ou umidade elevada.
11. Para limpeza use um pano macio seco ou ligeiramente umedecido com água. Não use agentes de limpeza ou abrasivos.

SAFETY INFORMATION

1. This package contains small parts, keep away from children until the product is assembled.
2. The instructions are generic, the figures may vary.
3. Read all instructions carefully before starting assembly.
4. Separate and store the ID tag.
5. Check if the volumes and quantities of pieces described in the manual are correct.
6. Identify the pieces and separate accessories.
7. The assembly of the product shall be made on a clean and flat surface. We recommend using the package itself to cover the floor in order not to damage the product.
8. Reserve a specific area to assemble the product.
9. Avoid shocks and contact with sharp objects.
10. Do not expose the furniture to excessive heat (direct sunlight), or high humidity.
11. For cleaning use a dry soft cloth or slightly moistened with water. Do not use cleaning agents or abrasives

INFORMACIÓN DE SEGURIDAD

1. Este paquete contiene piezas pequeñas, mantenga alejado de los niños hasta que el producto esté montado.
2. Las instrucciones son genéricas, los dibujos pueden variar.
3. Lea todas las instrucciones cuidadosamente antes de empezar el montaje.
4. Separar y almacenar la etiqueta de identificación.
5. Verifique si los volúmenes y cantidades de las piezas descritas en el manual están correctas.
6. Identificar las piezas y separar los accesorios.
7. El montaje del producto se efectuará sobre una superficie limpia y plana. Se recomienda usar el propio envase para cubrir el suelo con el fin de no dañar el producto.
8. Reserve una área específica para el montaje del producto.
9. Evitar los golpes y el contacto con objetos afilados.
10. No exponga el mueble a un calor excesivo (luz solar directa), o alta humedad.
11. Para la limpieza utilice un paño suave y seco o ligeramente humedecido con agua. No utilice productos de limpieza o abrasivos

Passo 3:

Coloque as Travessas do Estrado N° 06 nas laterais, fixe-as utilizando Parafusos 4,0 x 40 CC Phillips 'B' e 'E'.
Fixe as peças N° 01 na peseira N° 03 e cabeceira N° 04 utilizando parafusos 5,0 x 50 CC Phillips 'A'.
Após fixação cole as Tampas Adesivas 12mm 'F'.

Step 3:

Put the pieces No. 07 on the pieces No. 01 and No. 02, fix them using 'B' and 'E'.
Fix the piece No. 01 on the No. 03 and No. 04 using 'A'.
After fixation, paste 'F'.

Paso 3:

Ponga los pedazos N° 07 en las partes No. 01 y No. 02, conéctelos 'B' y 'E'.
Fije la pieza No. 01 en el No. 03 y No. 04 utilizando "A".
Después de la fijación, pegar 'F'.

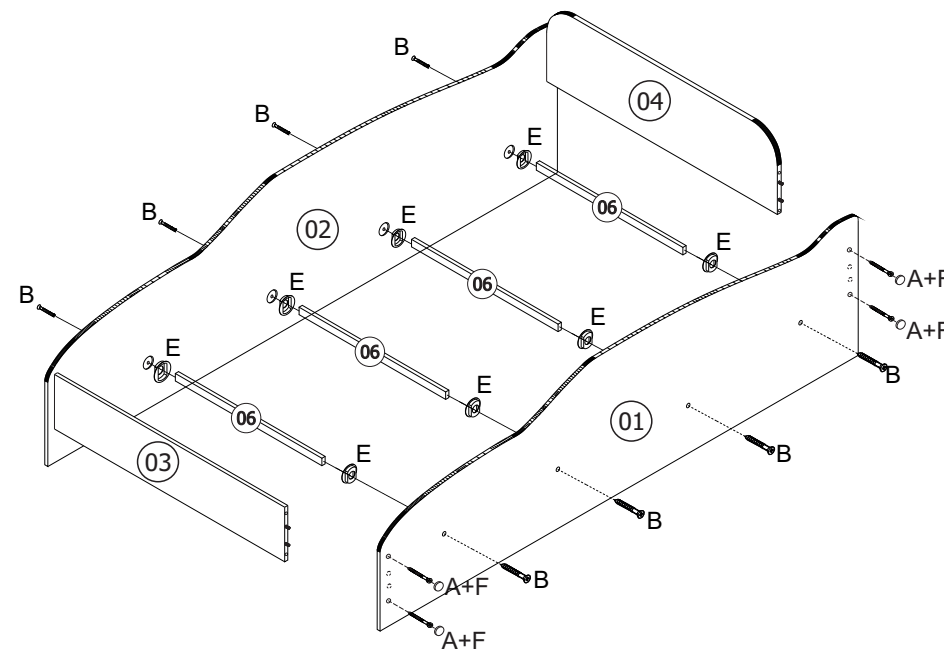

A 04 und. Parafuso 5,0 x 50 CC Phillips Screw 5.0 X 50CC Phillips Tornillo 5.0 X 50CC Phillips	B 08 und. Parafuso 4,0 x 40 CC Screw 4.0 x 40 CC Tornillo 4.0 x 40 CC
F 04 und. Tampa Adesiva 12 mm Adhesive label 12mm Tapa adhesiva 12mm	E 08 und. Suporte Plástico Plastic Support Soporte plástico

Passo 2:

Fixe a peça N° 02 na Peseira N° 03 e Cabeceira N° 04 utilizando Parafusos 5,0 X 50 CC Phillips 'A'. Após a fixação, cole as Tampas Adesivas 12mm 'F'.



Step 2

Fix the piece No. 02 on the pieces No. 03 and No. 04 using 'A'. After fixation, paste 'F'.

Paso 2:

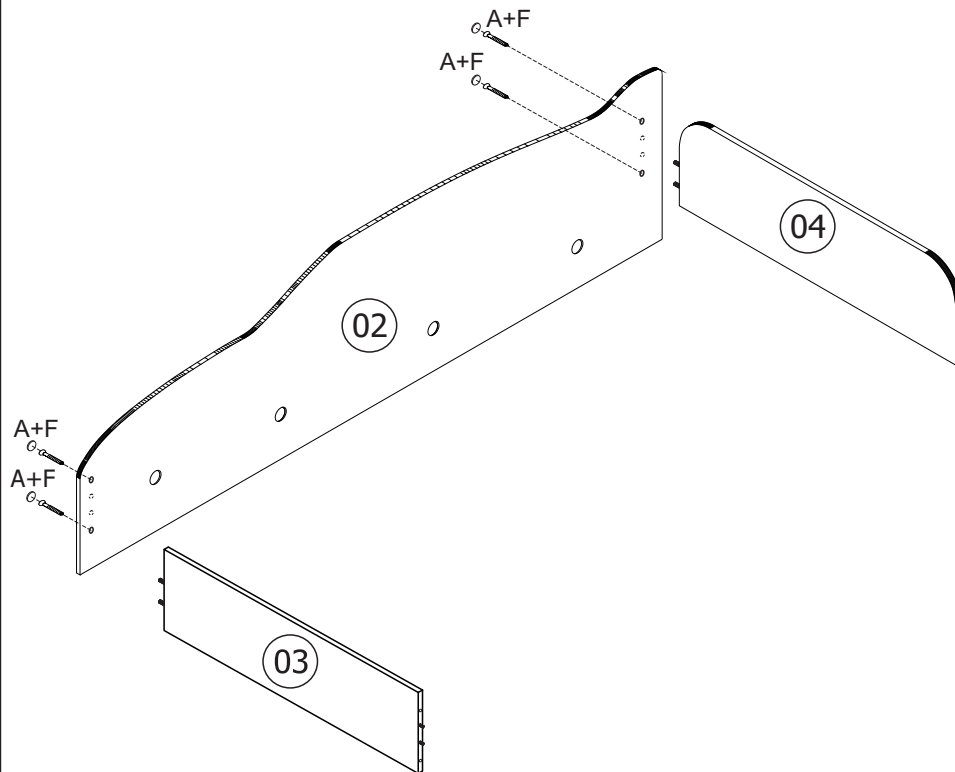
Fije la pieza No. 02 en las partes No. 03 y No. 04 utilizando "A". Después de la fijación, pegar 'F'.

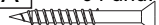

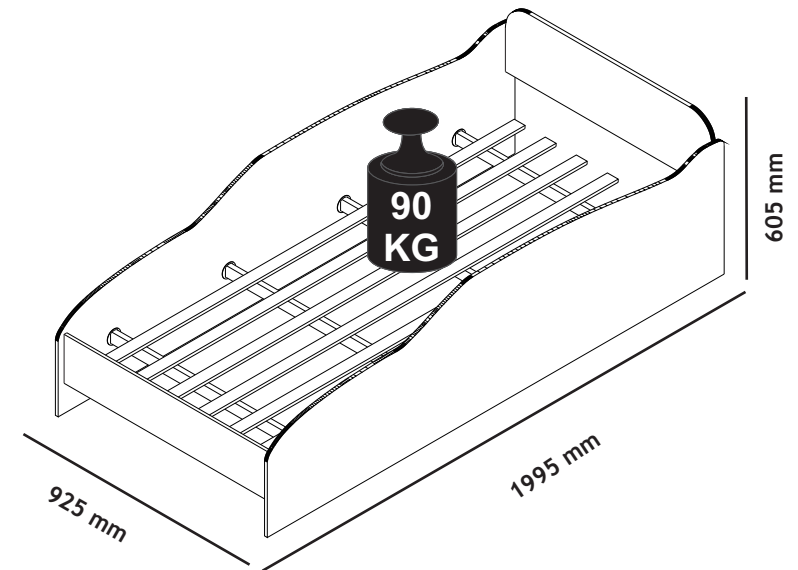

A	04 und.
	Parafuso 5,0 x 50 CC Phillips Screw 5,0 X 50CC Phillips Tornillo 5,0 X 50CC Phillips
F	04 und.
	Tampa Adesiva 12 mm Adhesive label 12mm Tapa adhesiva 12mm

PESO SUPORTADO / DIMENSÕES DO PRODUTO MONTADO SUPPORTED WEIGHT / DIMENSIONS ASSEMBLED PRODUCT PESO SOPORTADO/ DIMENSIONES PRODUCTO ARMADO

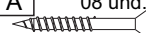
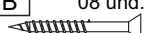
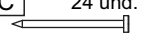
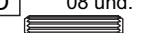
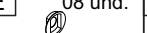
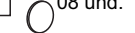

FERRAGENS / IRONMONGERY / HERRAJES

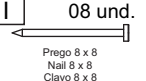
A	08 und.	B	08 und.	C	24 und.	D	08 und.	E	08 und.	F	08 und.
	Parafuso 5,0 x 50 CC Phillips Screw 5,0 X 50CC Phillips Tornillo 5,0 X 50CC Phillips		Parafuso 4,0 x 40 CC Screw 4,0 x 40 CC Tornillo 4,0 x 40 CC		Prego 12 x 12 Nail 12 x 12 Clavo 12 x 12		Cavinha Madeira 6 X 30 Dowel 6 x 30 Clavija 6 x 30		Suporte Plástico Plastic Support Soporte plástico		Tampa Adesiva 12 mm Adhesive label 12mm Tapa adhesiva 12mm
G	01 und.	H	04 und.	I	08 und.						
	Etiqueta Móveis Estrela Label Etiqueta		Sapata Retangular 50 x 12 Shoes Rectangular 50x12 Zapata Rectangular 50x12		Prego 8 x 8 Nail 8 x 8 Clavo 8 x 8						

FERRAGENS ESCALA REAL / REAL SCALE IRONMONGERY / HERRAJES EN TAMAÑO COMPLETO

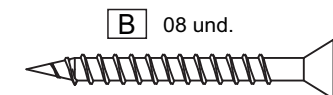
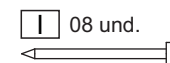
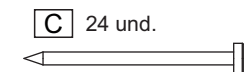
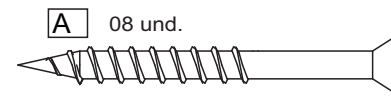

IDENTIFICAÇÃO DAS PEÇAS / IDENTIFICATION OF PARTS / IDENTIFICACIÓN DE LAS PIEZAS

CÓD.	IDENTIFICAÇÃO DAS PEÇAS	IDENTIFICATION OF PARTS	IDENTIFICACIÓN DE LAS PIEZAS	QTD
01	Lateral Direita	Right Side	Lado Derecho	01
02	Lateral Esquerda	Left Side	Lado Izquierdo	01
03	Peseira	Footboard	Piecero	01
04	Cabeceira	Headboard	Cabecera	01
05	Longarina	Stringer	Zanca	06
06	Travessa do Estrado	Bed slat support	Travesa del estrado	04

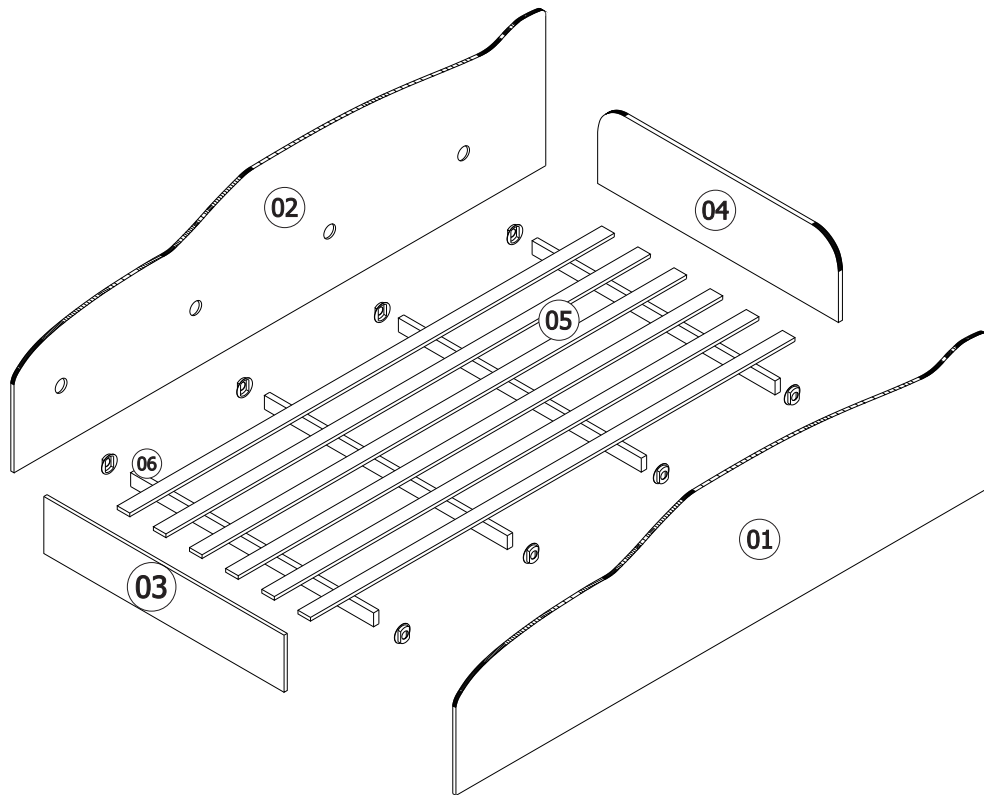

ASSISTÊNCIA TÉCNICA

Ao solicitar assistência técnica, informe o número da peça, nome e cor do produto e a data de fabricação do lote que se encontra carimbado na peça nº 05.

TECHNICAL ASSISTANCE

When request the technical assistance, please inform the number of the piece name and color of the product and also the batch manufacturing date, that is stamped on the piece nº 05.

ASISTENCIA TÉCNICA

Al solicitar la asistencia técnica, informe el número de la pieza, el nombre y el color del producto y también la fecha de fabricación del lote, que se estampa en la pieza nº 05.

04

MONTAGEM DO PRODUTO / PRODUCT ASSEMBLY / MONTAJE DEL PRODUCTO

Passo 1:

PASSO / STEP / PASO 1

Prepare as peças N°01, 02, 03 e 04, utilizando 'D', 'H', e 'I'.

Prepare the pieces N°01, 02, 03 and 04 using 'D', 'H' and 'I'.

Preparare las piezas N°01, 02, 03 y 04 utilizando 'D', 'H', y 'I'.

D	08 und.	H	04 und.	I	08 und.
					
Cavilha Madeira 6 X 30 Dowel 6 x 30 Clavija 6 x 30		Sapata Retangular 50 x 12 Shoes Rectangular 50x12 Zapata Rectangular 50x12		Prego 8 x 8 Nail 8 x 8 Clavo 8 x 8	

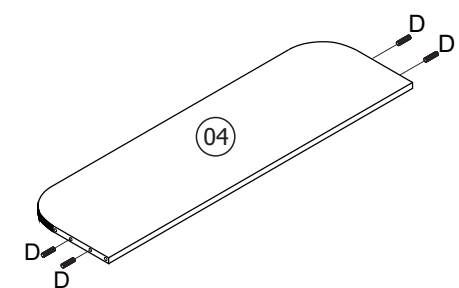
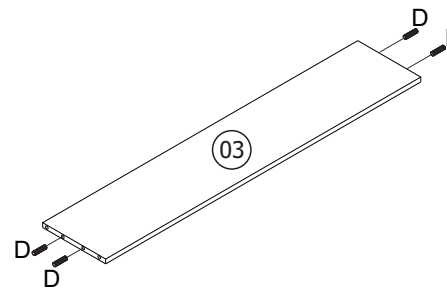
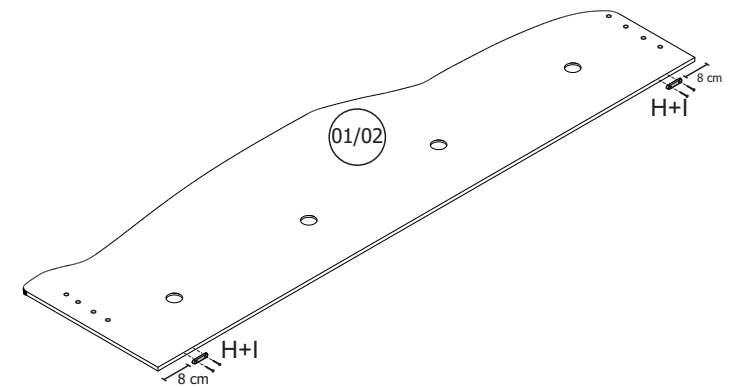

05